

### 5.3.1 TECHNICAL DATA

**MAX OPERATING PRESSURE (PS):**

(carbon steel) 100 – 160 – 210 – 250 – 350 bar  
 (stainless steel) 100 bar (other, upon request)

**PRESSURE TEST (PT):** 1,43 x PS

**NOMINAL CAPACITIES:** litres

0.075 - 0.16 - 0.25 - 0.32 - 0.5 - 0.75 - 1 - 1.4 - 2 - 2.8 - 3.5

**WORKING TEMPERATURE:** -40 ÷ +80 °C

**COMPRESSION RATIO (Po : P2):** max 1 : 8; see Tab.5.3d

**FLUID VISCOSITY RANGE:** 10 ÷ 400 cSt

**RECOMMENDED VISCOSITY:** 36 cSt

**FLUID CONTAMINATION DEGREE:**

class 21/19/16 according to ISO 4406/99

**BODY MATERIAL:** - carbon steel shell painted with a black rust inhibitor coat  
 - stainless steel AISI 316L

**FILLING VALVE MATERIAL (internal screw):**

- galvanized carbon steel in compliance with Directive 2002/95/CE (RoHS) to resist to corrosion  
 - stainless steel AISI 316L

**DIAPHRAGM MATERIAL:**

- P = Nitrile rubber (NBR)  
 - Y = Epichlorohydrin (ECO)

See Table 5.3c and /or Chapter 1.5

**FILLING VALVE CONNECTION:**

- M28 x 1.5  
 - without and closed

**FLUID PORT CONNECTION:**

- internal thread:  
 1/2" - 3/4" BSP ISO228  
 - external thread: M33x1.5  
 M45x1.5

See Table 5.3d

**FLOW RATE:** see Table 5.3d

**WEIGHT:** see Table 5.3d

### 5.3.2 "AMS" DIAPHRAGM ADVANTAGES

- high compression ratio
- dirt tolerant
- light weight
- compact
- simple construction
- quick response
- permanently sealed for maintenance free operation
- works well on low lubricity fluids
- quick, easy installation and replacement
- can be mounted in any position
- long service life
- low cost



5.2a

### 5.3.3 HYDRAULIC SYMBOL

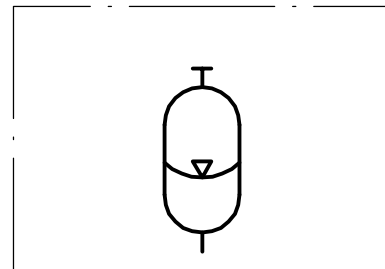

5.2b

### 5.3.4 DESCRIPTION

The welded type diaphragm accumulators cannot be repaired, as they are specially designed for high quantity and economical applications, where it is more practical to replace the unit rather than refurbishing it. These accumulators consist of a shell manufactured with a high strength alloy steel and a welded electron-beam.

The flexible diaphragm provides excellent gas and fluid separation. Diaphragm are available in two compounds:

- "P" nitrile (NBR)
- "Y" hydrin (ECO)

The button closes the fluid port when the accumulator is fully discharged to prevent diaphragm extrusion.

The fluid port is available provided with two types of connections:

- "G" BSP UNI228 female
- "W" BSP UNI228 female and external metric male

The gas valve is available in two versions:

- "VT" fixed pre-charge
- "VM" metric M28x1.5 gas valve and leak-free. It offers flexibility of checking or charging the accumulator (see charging kit type PCM).

This rugged gas valve features an internal hexagonal locking screw with sealing washer.

Diaphragm accumulators type AMS are then preferably used as shock absorbers and pulsation dampeners in the following sectors: industrial, machine tools, furniture and agriculture.

Compared to other accumulator types, the diaphragm ones have the highest energy density (energy content / mass). This feature is due to the spherical shape of the accumulator shell.

For the diaphragm accumulators, you can choose any type of installation. The preferred assembly is, however, the vertical one.

### 5.3.5 DIAPHRAGM - TEMPERATURE - LIQUID COMPATIBILITY

When selecting the accumulator variant, pay attention to the following non-binding notes with regard to hydraulic fluid, diaphragm material and the permissive temperature range.

Code letter	Polymer	ISO	Temperature range (°C)	Some of the liquids compatible with the polymer
P	Standard nitrile (Perburan)	NBR	-20 ÷ +80	Idrocarburi alifatici (propano, butano, benzina, olii, grassi minerali, carburante diesel, olio combustibile, kerosene), grassi ed olii minerali, fluidi HFA - HFB - HFC, molti acidi diluiti, alcali, soluzioni saline, acqua, acqua glicole
Y	Epichloridrin	ECO	-30 ÷ +110	Mineral oils and greases, aliphatic hydrocarbons (propane, butane and gasoline), silicone oils and greases, water at room temperature, resistance to ozone, aging and weathering.

For other hydraulic fluid and/or temperatures, please consult us.

5.3c

## 5.3.6 ORDER CODE

**AMS 1 P 210 C G 4 - 0 - VM / 30**

Series
Diaphragm accumulator = <b>AMS</b>

Nominal capacity (litres)
0,075 = <b>0,075</b>
0,16 = <b>0,16</b>
0,32 = <b>0,32</b>
0,5 = <b>0,5</b>
0,75 = <b>0,75</b>
1 = <b>1</b>
1,4 = <b>1,4</b>
2 = <b>2</b>
2,8 = <b>2,8</b>
3,5 = <b>3,5</b>

Diaphragm material
Gomma nitrilica (NBR) = <b>P</b>
Epicloridrina (ECO) = <b>Y</b>

Max working pressure (PS)		
Capacity litres	Carbon steel	Stainless steel
0,075 =	<b>250</b>	<b>100</b>
0,16 =	<b>250</b>	<b>100</b>
0,32 =	<b>210</b>	<b>100</b>
0,5 =	<b>210</b>	<b>100</b>
0,75 =	<b>160-210-350</b>	<b>100</b>
1 =	<b>210</b>	<b>100</b>
1,4 =	<b>210 - 350</b>	<b>100</b>
2 =	<b>100 - 250</b>	<b>100</b>
2,8 =	<b>250 - 350</b>	<b>100</b>
3,5 =	<b>250 - 350</b>	<b>-</b>

### Special variants on request

### Types normally available from stock:

- AMS0.32P210CG4-0-VM/30
- AMS0.5P210CG4-0-VM/30
- AMS0.75P210CG4-0-VM/30

Precharge pressure (bar)
Standard 30 bar = <b>0 ÷ 130</b> (max 130 bar)

Gas side connection
Standard filling valve thread M28x1.5 = <b>VM</b>
Without pre-charge valve with fixed pre-charge calibration = <b>VT</b>

Test and certification
Factory testing = <b>0</b>
GOST-R (Russia) = <b>1</b>
ML (China) = <b>3</b>
PED97/23/EC(for capacity 1,5-2,5 l) = <b>8</b>
ATEX 94/9EC = <b>9</b>
RTN Passport (Russia) = <b>11</b>
Algeria passport = <b>12</b>

Dimension of connection side
For the type of connection:
G (for capacity 0.075 ÷ 2 l) 1/2" = <b>4</b>
G (for capacity 2 ÷ 3.5 l) 3/4" = <b>5</b>

Fluid port connection
BSP ISO 228 Female = <b>G</b>
BSP ISO 228 Female and metric male = <b>W</b>
male M33x1.5 for capacity 0.5-0.75-1-1.4 - 2 l
male M45x1.5 for capacity 2.8 -3.5

Body material
Carbon steel = <b>C</b>
Stainless steel (100 bar) = <b>X</b>

## 5.3.7 DIMENSIONS

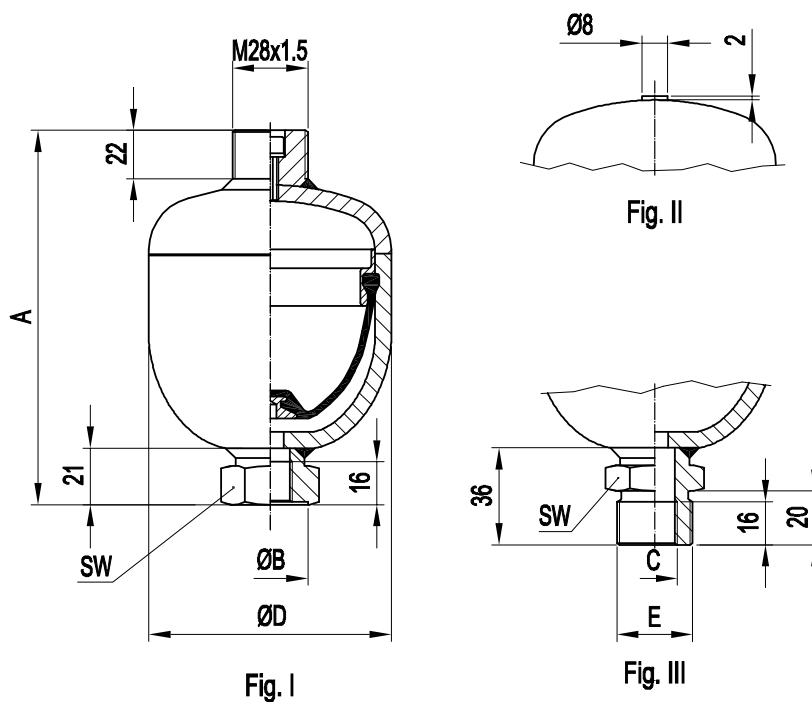

5.3d

Accumulator type AMS	Fig.	Nominal gas value litres	Actual gas value litres	Working pressure bar	PED category for the liquids of group 2	Maximum differential pressure * bar	Flow rate ** l/min	Maximum compression ratio Po/P2	A mm	Ø B mm	C mm	Ø D mm	E mm	SW mm	Dry weight Kg		
AMS 0,075	I - II	0,075	0,075	250	Art.3 (3)	210	20	1 : 8	111	29	1/2"	64	-	32	0,7		
AMS 0,16	I - II	0,16	0,16	250	Art.3 (3)	210	20	1 : 8	120	29	1/2"	75	-	32	1		
AMS 0,32	I - II	0,32	0,32	210	Art.3 (3)	140	40	1 : 8	140	29	1/2"	93	-	32	1,4		
AMS 0,5	I-II-III	0,5	0,5	210	Art.3 (3)	175	50	1 : 8	152	34	1/2"	106	M33x1,5	41	2		
AMS 0.75	II-III	0.75	0.75	160	Art.3 (3)	120	50	1 : 8	166	34	1/2"	121	M33x1.5	41	2.6		
	210			175		166			122			2.6					
	350			150		168			13			4.4					
AMS 1	I-II-III	1	1	210	Art.3 (3)	170	50	1 : 8	180	34	1/2"	136	M33x1.5	41	3.5		
AMS 1.4	I-II-III	1.4	1.4	140	I	100	50	1 : 8	199	34	1/2"	150	M33x1.5	41	4.2		
				210		120			191			148			5.4		
				350		150			199			160			7.4		
AMS 2	I-II-III	2	2	100	I	80	50	1 : 8	213	34	1/2"	163	M33x1.5	41	3.5		
				210		120			240		1/2"	144			M33x1.5	41	4.2
				250		140			251		3/4"	155			-	41	7.5
				350		200			219		3/4"	180			-	55	11.3
AMS 2.8	I-II-III	2.8	2.8	210	II	100	50	1 : 4	213	34	1/2"	163	M33x1.5	41	8.2		
				250		140			268		3/4"	174			-	41	10
				350		200			264		3/4"	180			M45x1.5	55	14.3
AMS 3.5	I-II	3.5	3.5	250	II	140	70	1 : 4	307	34	3/4"	174	-	41	11		
				350		200			304		3/4"	180			M45x1.5	55	16

\* The maximum differential pressure is the maximum allowable difference between the maximum pressure and the minimum working pressure (P2-P1) to have an infinite life cycle of the accumulator (greater than 2,000,000 cycles).

\*\* Flow rate measured using mineral oil with viscosity of 36 cSt at 50°C and  $\Delta P = 5$  bar

### 5.3.8 EUROPE MARKET

All hydraulic accumulators are pressure vessels and are subject to the national regulations and directives, valid at the place of installation.

Diaphragm accumulator type AMS, up to and including 1 litre, must not be CE marked.

For diaphragm accumulator type AMS, greater than 1 litre, every shipping batch is provided with a conformity declaration and use and maintenance instructions and/or all documents requested.

All vessel categories (see Table 5.1d) must be protected by means of a pressure relief valve in accordance with Directive 97/23/EC.

### 5.3.9 SPARE PARTS CODE

Item	Description	AMS 0.075 ÷ 2,8
1	Gas valve VM	V2220-CP

5.2e

### 5.3.10 ACCESSORIES

For clamps, see Cap.7

For pre-loading and charging set, see Cap.11.2

For pulse damper adapters, see Cap.12.1

### 5.3.11 COMMISSIONING AND MAINTENANCE

#### Delivery condition

Diaphragm accumulators are delivered pre-charged with nitrogen at a pressure of 30 bar or at value of pressure required at time of order.

The pre-charge value is still on the nameplate of the accumulator.

Depending on the size and quantity ordered, the diaphragm accumulators are shipped in boxes or in cartons or on pallets, or wooden boxes on request.

Unless otherwise required, certificates and documentation are provided together with the accumulators.

#### Handling

The original packaging is suitable for handling and general storage.

Where necessary, you should use suitable lifting equipment to support the weight of the accumulators.

Protect from impact, however, the packaging and handle it with care.

#### Storage

During storage in the warehouse, leave the product in its original packaging, keeping it away from heat sources and naked flames. The storage temperature should be between +10 and +40°C.

After six years of storage, it is essential to proceed with the replacement of all elastomeric parts before the commissioning.

#### Marking on the nameplate of the accumulator

With reference to the PED 97/23/EC classification, Article 3, Paragraph 3 and / or risk categories I or II according to the amount and maximum working pressure, the accumulator indicates the following

- logo, name and country of the manufacturer
- product code
- Month / year of production
- Serial number

- Maximum PS pressure and PT test pressure in bar
- Min. and max. TS working temperature in Celsius
- Volume V in litres
- Group of fluids allowed (II)
- CE marking (by volume exceeding 1 litre) with the identification number of the notified body
- Pre-charge pressure in bar

#### It is strictly forbidden to:

- engrave or permanently stamp the surfaces of the accumulator shell and / or carry out other operations that could affect or change the mechanical properties of the accumulator
- use the accumulator as a structural element: it should not be subjected to stresses or loads
- change the data of the nameplate and / or accumulator without the permission of the manufacturer
- use a (dangerous) fluid of Group 1 with equipment designed and manufactured for fluids of Group 2.

#### Installation

Before installation, you must perform a visual check to verify that the accumulator has not suffered any damage during shipping / handling. Verify that the requested type matches with what stamped on the nameplate.

We recommend using the accumulator with a suitable safety valve (see section 8) or a security safety block type BS (see section 9). This device provides user and equipment protection against possible damage caused by pressure surges, and also makes the maintenance of the accumulator easier, so facilitating the interception and the discharge.

Provide for a clearance of 200 mm above the gas pre-charge valve to allow access to and control of the pre-charge equipment (see section 11.2).

The accumulators type AMS may be installed in any position from horizontal to vertical (preferably with the pre-charge valve at the top), and the nameplate must be visible.

Proceed to the assembly so that no abnormal force affects the pipes connected directly or indirectly to the accumulator, so we recommend the use of supporting components and also fastening (please see Chapter 7) to avoid the transmission of vibrations.

Make sure the fluid is compatible with the elastomer of the diaphragm. Check that the max. allowed accumulator pressure is equal to or greater than that of the hydraulic circuit and that the temperature during operation is maintained within the range expected.

Make sure the fluid does not contain contaminants and/or abrasive.

#### Pre-charge of nitrogen

Normally, the diaphragm accumulators are delivered pre-charged with pressurized gas. The pre-charge of gas can be controlled and / or adjusted before or after installation of the accumulator in the hydraulic circuit. For the pre-charge, use only industrial dry nitrogen with a purity of min. 99%. It is important to use the nitrogen from a cylinder equipped with a pressure reducing valve (see Chap.11.3). Use the EPE pre-charge and charging set type PCM to check the charging pressure Calculated Against the pressure, and adjust if necessary.

If the pre-charge pressure is lower than required, connect the inflation tube on one side and the other of the equipment. Connect it to the cylinder of nitrogen or to the pressure reducer. Slowly enter the nitrogen in the accumulator until reaching a pressure slightly higher than that set (+

10 ÷ 15%).

Close the cylinder and remove the connecting pipe from the equipment; wait until the gas temperature has stabilized (1 hour) and calibrate the pressure, discharging the excess gas. Make sure that the gas pipe is not subject to losses and, if necessary, use soap and water.

#### Hydraulic pressurization

- Check that the pre-charge pressure is adequate for the application
- Ensure that the hydraulic pressure never exceeds the max. (PS) allowed and shown on the accumulator shell.

To avoid this risk, use a safety item (see Chap. 9).

#### Maintenance

- Periodically check the pre-charge pressure of the gas: after the commissioning, check after 2-3 weeks of operation and if there were no leaks, repeat the operation after 3 months; if the pressure at the same temperature was stable, repeat the test at annual intervals. For heavy-duty applications, check the pre-charge every 6 months.
- Periodically (annually) carry out a visual inspection of the accumulator in order to detect any early signs of deterioration such as corrosion, deformation, etc.
- Comply with the requirements of the regulations concerning the verification of the functionality of the equipment according to the country of installation of the accumulator.

#### Disassembly

If for failure, scheduled check or retest it is necessary to remove the accumulator from the system, prior to removal, isolate the accumulator from the installation and discharge pressure of the liquid.

All diaphragm EPE accumulators of the AMS series may be repaired.

#### Repair

It may consist in replacing the pre-charge valve. For reasons of functionality and security, it is recommended to use only original spare parts. Before starting the repair, drain completely the nitrogen contained in the accumulator.

#### Disassembly

- Fix the accumulator.
- Remove the pre-charge valve (after having discharged completely the nitrogen).

#### Refitting

After thorough cleaning, check and replace the pre-charge valve.

#### Pre-charge

- Screw the pre-charge PCM equipment on the gas valve.
- Connect the equipment to the cylinder of nitrogen or to the pressure reducer with the inflation tube.
- Slowly enter the nitrogen in the accumulator until reaching a pressure slightly higher than the set value (+ 10 ÷ 15%).
- Close the cylinder and remove the connecting pipe from the equipment.
- Wait until the gas temperature has stabilized (1 hour).
- Calibrate the pressure discharging the excess gas.

#### Demolition and recycling of the accumulator

Before accumulator demolition or recycling, you should always discharge completely the pre-charge pressure and remove the gas valve.

If you need, proceed decontaminating in relation to the fluid used prior to demolition.

Reproduction Is Forbidden.

In The Spirit Of Continuous Improvement, Our Products May Be Changed.