

Duplex tank-mounted return line filter, with filter element in accordance with DIN 24550

Type 10TDN0040 ... 1000; 10TD2000; 2500

RE 51454

Edition: 2015-05

Replaces: 01/15



H8062_d

- ▶ Size according to **DIN 24550**: 0040 to 1000
- ▶ Additional sizes: 2000, 2500
- ▶ Component series 1X
- ▶ Nominal pressure 10 bar [145 psi]
- ▶ Connection up to 3"
- ▶ Operating temperature -10 °C to +100 °C [14 °F to 212 °F]

Features

The tank mounted return line filters are designed for installation on fluid tanks. Their function is to separate solid materials from fluids.

They distinguish themselves by the following:

- ▶ Filter for tank mounting, switchable
- ▶ Special highly efficient filter materials
- ▶ Filtration of very fine particles and high dirt holding capacity across a broad pressure differential range
- ▶ High collapse resistance of the filter elements
- ▶ Optionally equipped with mechanical optical maintenance indicator with memory function
- ▶ Various, optional electronic switching elements, modular design
- ▶ Filters are equipped as standard with a bypass valve integrated in the filter housing
- ▶ Optional measuring port

Contents

Features	1
Ordering code filter	2, 3
Preferred types	4
Ordering code accessories	5 ... 7
Symbols	8
Function, section	9
Technical data	10, 11
Compatibility with permitted hydraulic fluids	11
Characteristic curves	12 ... 19
Dimensions	20 ... 26
Ordering code spare parts	27 ... 30
Assembly, commissioning, maintenance	31, 32
Tightening torques	33
Directives and standardization	34, 35
Environmental safety and recycling	35

Ordering code filter

01	02	03	04	05	06	07	08	09	10	10	10	10	10	10	10	10
10TD			- 1X /		A00	-	-	-	-	-	-	-	-	-	-	-

Series

01	Duplex tank mounted return line filter 10 bar [145 psi]	10TD
----	---------------------------------------------------------	------

Filter element

02	with filter element according to DIN 24550 (only with frame size 0040-1000)	N
----	------------------------------------------------------------------------------------	---

Size

03	TDN... (Filter element according to DIN 24550)	0040 0063 0100 0160 0250 0400 0630 1000
	TD... (Filter elements according to Bosch Rexroth standard)	2000 2500

04	Component series 10 ... 19 (10 ... 19: unchanged installation and connection dimensions)	1X
----	-------------------------------------------------------------------------------------------------	----

Filter rating in μm

05	Nominal	Paper, not cleanable	P10 P25
	Nominal	Stainless steel wire mesh, cleanable	G10 G25 G40 G60 G100
	Absolute (ISO 16889; $\beta_{x(e)} \geq 200$)	Glass fiber material, not cleanable	H3XL H6XL H10XL H20XL
	Absolute (ISO 16889; $\beta_{x(e)} \geq 200$)	Water-absorbing, not cleanable	AS6 AS10 AS20

Pressure differential

06	Max. admissible filter element pressure differential: 30 bar [435 psi], filter with bypass valve	A00
----	---------------------------------------------------------------------------------------------------------	-----

Maintenance indicator (1 unit per filter side)

07	Without maintenance indicator - bypass release pressure 3.5 bar [51 psi]	0
	Manometer ¹⁾ 0...6 bar [0...87 psi] opposite of connection - bypass release pressure 3.5 bar [51 psi]	MB
	Maintenance indicator, cover mounted, aluminum, mech./optical, switching pressure 2.2 bar [32 psi] with additional manometer ¹⁾ 0...0.6 bar [0...0.87 psi] opposite of connection - bypass release pressure 3.5 bar [51 psi]	MBV2.2
	Maintenance indicator, polyamide, mech./optical, switching pressure 2.2 bar [32 psi] – bypass release pressure 3.5 bar [51 psi]	P2.2
	Maintenance indicator, aluminum, mech./optical, switching pressure 0.8 bar [11.6 psi] – bypass release pressure 3.5 bar [51 psi]	V0.8
	Maintenance indicator, aluminum, mech./optical, switching pressure 1.5 bar [21.8 psi] – bypass release pressure 3.5 bar [51 psi]	V1.5
	Maintenance indicator, aluminum, mech./optical, switching pressure 2.2 bar [32 psi] – bypass release pressure 3.5 bar [51 psi]	V2.2

¹⁾ When using a manometer, the maximum permissible operating pressure is reduced to 6 bar [87 psi].

Ordering code filter

01	02	03	04	05	06	07	08	09	10	10	10	10	10	10	10	10
10TD			- 1X /		A00	-	-	-	-	-	-	-	-	-	-	-

Seal

08	NBR seal	M
	FKM seal	V

Connection

09	Frame size	0040-0100	0160-0250	0400-0630	1000-2500	
	Connection					
	G1	●				R4
	G1 1/4		X			R5
	G1 1/2		●			R6
	SAE 2 1/2" - 3000 psi			●		S9
	SAE 3" - 3000 psi				●	S10
	SAE 16"	X				U9
	SAE 20"		X			U5
<input checked="" type="checkbox"/> Standard connection <input type="checkbox"/> optional connection						

Supplementary information (Multiple specifications possible)

10	Breathing filter with oil mist separator (only size 0040-0100)	FN
	Additional screw coupling, G1/4, opposite the intake (not in conjunction with a manometer)	M
	Installation plate (only NG0400-2500)	MP
	without bypass valve	NB
	Outlet pipe L110 mm [4.33 inch] (only NG0040-0100, from NG0160 see chapter "Accessories")	R110
	Outlet pipe L150 mm [5.91 inch] (only NG0040-0100, from NG0160 see chapter "Accessories")	R150
	Outlet pipe L250 mm [9.84 inch] (only NG0040-0100, from NG0160 see chapter "Accessories")	R250

Order example:

10TDN0040-1X/H10XLA00-P2,2-M-R4

Material no. R928048600

Further models on request.

Preferred types

Filter rating 3 µm, 6 µm, 10 µm and 20 µm

Filter type	Flow in l/min [gpm] with $v = 30 \text{ mm}^2/\text{s}$ [142 SUS] and $\Delta p = 0.5 \text{ bar}$ [7.25 psi] ¹⁾	Connection	Material no.	Connection	Material no.
10TDN0040-1X/H3XLA00-P2,2-M-...	23 [6.1]	..R4	R928051464	..U9	R928051605
10TDN0063-1X/H3XLA00-P2,2-M-...	35 [9.2]	..R4	R928051465	..U9	R928051606
10TDN0100-1X/H3XLA00-P2,2-M-...	52 [13.7]	..R4	R928051466	..U9	R928051607
10TDN0160-1X/H3XLA00-P2,2-M-...	105 [27.7]	..R6	R928051467	..U5	R928051608
10TDN0250-1X/H3XLA00-P2,2-M-...	160 [42.3]	..R6	R928051468	..U5	R928051609
10TDN0400-1X/H3XLA00-P2,2-M-...-MP	290 [76.6]	..S9	R928051469		
10TDN0630-1X/H3XLA00-P2,2-M-...-MP	410 [108.3]	..S9	R928051470		
10TDN1000-1X/H3XLA00-P2,2-M-...-MP	560 [147.9]	..S10	R928051471		
10TD2000-1X/H3XLA00-P2,2-M-...-MP	900 [237.7]	..S10	R928051472		
10TD2500-1X/H3XLA00-P2,2-M-...-MP	1100 [290.6]	..S10	R928051473		
10TDN0040-1X/H6XLA00-P2,2-M-...	37 [9.8]	..R4	R928051395	..U9	R928051600
10TDN0063-1X/H6XLA00-P2,2-M-...	49 [12.9]	..R4	R928051396	..U9	R928051601
10TDN0100-1X/H6XLA00-P2,2-M-...	70 [18.5]	..R4	R928051397	..U9	R928051602
10TDN0160-1X/H6XLA00-P2,2-M-...	150 [39.6]	..R6	R928051398	..U5	R928051603
10TDN0250-1X/H6XLA00-P2,2-M-...	200 [52.8]	..R6	R928049477	..U5	R928051604
10TDN0400-1X/H6XLA00-P2,2-M-...-MP	410 [108.3]	..S9	R928051399		
10TDN0630-1X/H6XLA00-P2,2-M-...-MP	510 [134.7]	..S9	R928051458		
10TDN1000-1X/H6XLA00-P2,2-M-...-MP	870 [229.8]	..S10	R928049321		
10TD2000-1X/H6XLA00-P2,2-M-...-MP	1250 [330.1]	..S10	R928051461		
10TD2500-1X/H6XLA00-P2,2-M-...-MP	1350 [356.5]	..S10	R928051463		
10TDN0040-1X/H10XLA00-P2,2-M-...	43 [11.3]	..R4	R928048600	..U9	R928051613
10TDN0063-1X/H10XLA00-P2,2-M-...	62 [16.4]	..R4	R928048601	..U9	R928051614
10TDN0100-1X/H10XLA00-P2,2-M-...	80 [21.1]	..R4	R928048602	..U9	R928051615
10TDN0160-1X/H10XLA00-P2,2-M-...	190 [50.2]	..R6	R928051508	..U5	R928051616
10TDN0250-1X/H10XLA00-P2,2-M-...	260 [68.7]	..R6	R928048604	..U5	R928051617
10TDN0400-1X/H10XLA00-P2,2-M-...-MP	460 [121.5]	..S9	R928048991		
10TDN0630-1X/H10XLA00-P2,2-M-...-MP	560 [147.9]	..S9	R928051424		
10TDN1000-1X/H10XLA00-P2,2-M-...-MP	970 [256.2]	..S10	R928048992		
10TD2000-1X/H10XLA00-P2,2-M-...-MP	1350 [356.6]	..S10	R928048993		
10TD2500-1X/H10XLA00-P2,2-M-...-MP	1450 [383.0]	..S10	R928048994		
10TDN0040-1X/H20XLA00-P2,2-M-...	62 [16.4]	..R4	R928051386	..U9	R928051595
10TDN0063-1X/H20XLA00-P2,2-M-...	80 [21.1]	..R4	R928051387	..U9	R928051596
10TDN0100-1X/H20XLA00-P2,2-M-...	95 [25.1]	..R4	R928048958	..U9	R928051597
10TDN0160-1X/H20XLA00-P2,2-M-...	260 [68.7]	..R6	R928051388	..U5	R928051598
10TDN0250-1X/H20XLA00-P2,2-M-...	320 [84.5]	..R6	R928051389	..U5	R928051599
10TDN0400-1X/H20XLA00-P2,2-M-...-MP	560 [147.9]	..S9	R928051390		
10TDN0630-1X/H20XLA00-P2,2-M-...-MP	630 [166.4]	..S9	R928051391		
10TDN1000-1X/H20XLA00-P2,2-M-...-MP	1270 [335.5]	..S10	R928051392		
10TD2000-1X/H20XLA00-P2,2-M-...-MP	1600 [422.7]	..S10	R928051393		
10TD2500-1X/H20XLA00-P2,2-M-...-MP	1680 [443.8]	..S10	R928051394		

¹⁾ Measured pressure differential across filter and measuring equipment in accordance with ISO 3968. The measured pressure differential at the maintenance indicator is lower.

Ordering code accessories

Electronic switching element for maintenance indicators

If an electronic switching element with signal suppression up to 30 °C [86 °F] is used (WE-2SPSU-M12X1, **R928028411**), it has to be ensured that the aluminum version of the mechanical-optical maintenance indicator **must** be used. These maintenance indicators are referred to in the filter type key as “V0.8”, “V1.5” or “V2.2”.

In this connection, also refer to the chapter “Maintenance indicator”.

The temperature-controlled signal processing does not work with mechanical-optical maintenance indicators made of polyamide, “P2.2”.

01	02	03
WE	-	-

Maintenance indicator

01	electronic switching element	WE
----	------------------------------	-----------

Type of signal

02	1 switching point	1SP
	2 switching points, 3 LED	2SP
	2 switching points, 3 LED and signal suppression up to 30 °C [86 °F]	2SPSU

Plug

03	Round plug-in connection M12x1, 4-pole	M12x1
	Rectangular connector, 2-pole, design A according to EN-175301-803, only possible with “1SP” type of signal.	EN175301-803

Material numbers of the electronic switching elements

With the “mechanical-optical maintenance indicator” option (V..., P...), two mechanical optical maintenance indicators are installed at the factory. So you must always order two electric switching elements as optional accessories.

Material no.	Type	Signal	Switching points	Plug	LED
R928028409	WE-1SP-M12x1	Changeover	1	M12x1	without
R928028410	WE-2SP-M12x1	Normally open (at 75%) / normally closed contact (at 100%)	2		3 pieces
R928028411	WE-2SPSU-M12x1				
R928036318	WE-1SP-EN175301-803	Normally closed contact	1	EN 175301-803	without

Ordering code accessories

(dimensions in mm [inch])

Mating connectors (max. admissible voltage: 50 V)

for electronic switching element with round plug-in connection M12x1

Mating connector suitable for K24 4-pole, M12x1 with screw connection, cable gland Pg9.

Material no. R900031155

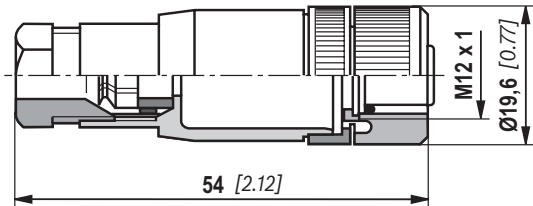

Mating connector suitable for K24-3m 4-pole, M12x1 with potted-in PVC cable, 3 m long.

Line cross-section: 4 x 0.34 mm²

Core marking: **1** brown **2** white
 3 blue **4** black

Material no. R900064381

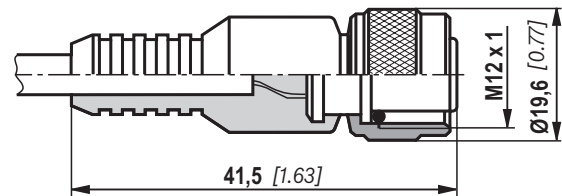

For more round plug-in connections and technical data refer to data sheet 08006.

Order example:

Tank-mounted return line filter with mechanical optical maintenance indicator for $p_{\text{nominal}} = 10 \text{ bar [145 psi]}$ size 0040, with filter element 10 μm and electronic switching element M12x1 with one switching point.

Filter with mech. optical maintenance indicator: 10TDN0040-1X/H10XLA00-P2,2-M-R4 **Material no.:** R928048600

Electr. switching element: WE-1SP-M12x1 **Material no.:** R928028409

Mating connector: Mating connector suitable for K24 4-pole, M12x1 with screw connection, cable gland Pg9 **Material no. R900031155**

Ordering code accessories

(dimensions in mm [inch])

Outlet pipe

The outlet pipe is push connected onto the filter bowl outlet piece. Correct seat is confirmed by an audible click. After the connection is made, the outlet pipe can no longer be removed.

Outlet pipe with push connection size 0040-0100

Material no.	Description
R928038744	ACC-R-10TEN0040-0100-R110
R928038745	ACC-R-10TEN0040-0100-R150
R928038746	ACC-R-10TEN0040-0100-R250

Outlet pipe with threaded connection from size 0160

Dimensions and range

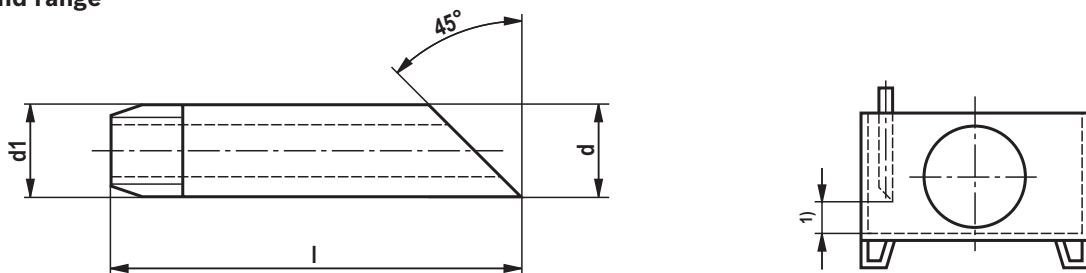

- ¹⁾ Recommended distance to tank bottom (unless otherwise specified): 60...160 mm [2.4...6.3 inch]
 From a pipe length of 400 mm [15.75 inch], we strongly recommend fixing the outlet pipe by means of a tank-internal pipe bracket.

DN	Dimensions				galvanized	ES (stainless)
	d	d1	l		Description: PIPE AB23-03/R...	Description: PIPE AB23-03/R... -ES
					Material no.	Material no.
40 [1.57]	48.3 [1.90]	R 1 1/2	250 [9.84]	1 1/2 L = 250	R900109501	R900062066
			400 [15.75]	1 1/2 L = 400	R900083146	R900074878
			800 [31.50]	1 1/2 L = 800	R900029854	-
			1300 [51.18]	1 1/2 L = 1300	R900302230	-
			2000 [78.74]	1 1/2 L = 2000	R900229461	-
50 [1.97]	60.3 [2.37]	R 2	400 [15.75]	2 L = 400	R900727174	R900987657
			800 [31.50]	2 L = 800	R900029856	R900226706
80 [3.15]	88.9 [3.50]	R 3	160 [6.30]	3 L = 160	R900062845	-
			200 [7.87]	3 L = 200	R900061785	R900062067
			350 [13.78]	3 L = 350	R900084137	-
			650 [25.59]	3 L = 650	R900076923	R900757513
			800 [31.50]	3 L = 800	R900029838	R900987653

Thread:

Whitworth pipe thread according to DIN 2999 part 1, poppet 1:16

Material/surface treatment:

St 33-1 according to DIN 17100/galvanized (B) according to DIN 2444
 1.4541

Order example/search term

Pipe according to DIN 2440 (ISO 65) with thread R 1 1/2 and L = 250 mm [9.84 inch], galvanized:

PIPE AB23-03/R 1 1/2 L = 250 material no. R900109501

Symbols

Tank-mounted return line filter

with bypass and mechanical indicator and / or manometer

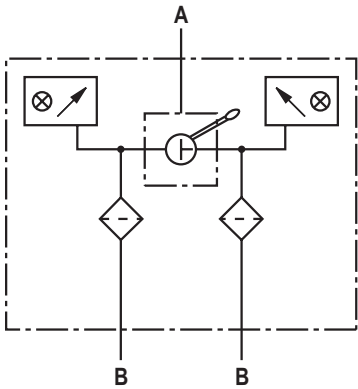
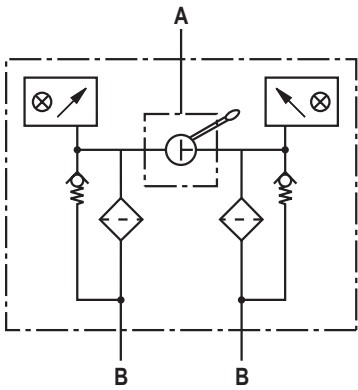

Tank-mounted return line filter

without bypass and mechanical indicator and / or manometer

electronic switching element
for maintenance indicator

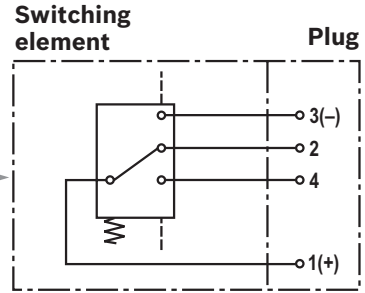

WE-1SP-M12x1

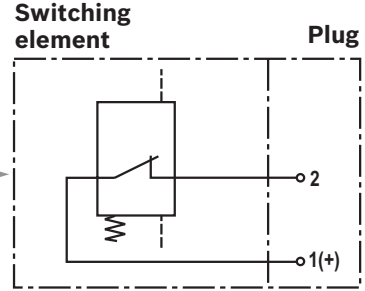

WE-1SP-EN175301-803

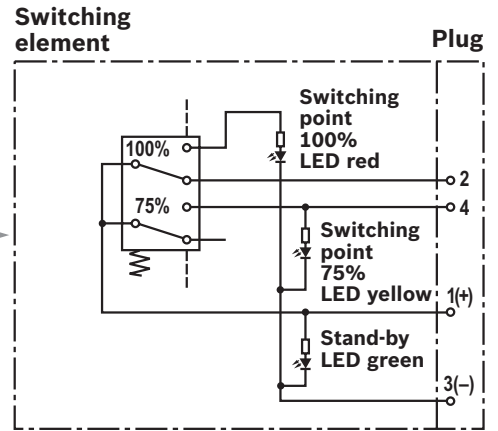

WE-2SP-M12x1

Circuit diagram drawn in plugged condition (operating state)

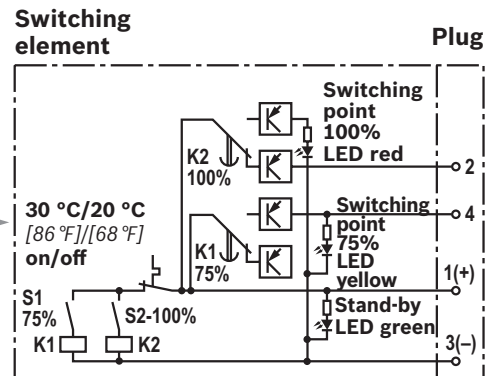

WE-2SPSU-M12x1

Circuit diagram drawn in plugged condition at temperature > 30 °C [86 °F] (operating state)

Function, section

The switchable tank mounted return line filter is located in the return line for direct attachment onto the tank of a hydraulic or lubrication system. It can also be used as filling or bypass filter. The filter basically consists of filter head (1) and switch-over fitting (2), filter bowl (3), cover (4), filter element (5) as well as a bypass valve (6), by default.

Optionally, the filter is equipped with mechanical optical maintenance indicator including memory function (7). An electronic switching element can be added to the mechanical/optical maintenance indicator in order to integrate the maintenance indicator.

The electronic switching element (8) must be attached to the mechanical/optical maintenance indicator (7) and held by means of a locking ring. The electronic switching elements are connected via a plug-in connector or a cable. The electronic switching element must be ordered separately. For every filter housing, a switching element is required.

Depending on the filter size, more additional functions are available - e.g. a breathing filter, surge protection (only for size 0040 - 0100) or outlet pipes in different lengths – in this connection, also refer to the chapter “Accessories”.

During operation, the hydraulic fluid reaches the filter housing via the inlet; here, it flows through the filter element from the outside to the inside and is cleaned according to the filter rating. Any dirt particles filtered out settle in the filter element. Via the outlet, the filtered hydraulic fluid enters the tank. In case of contamination, the necessary filter element exchange is displayed by the relevant maintenance indicator. Within the course of this exchange, you should also exchange the breathing filter element if equipped (only with size 0040-0100). The system is manually switched to the clean filter element by means of the switch-over fitting. Continuous flow is guaranteed during the switching process.

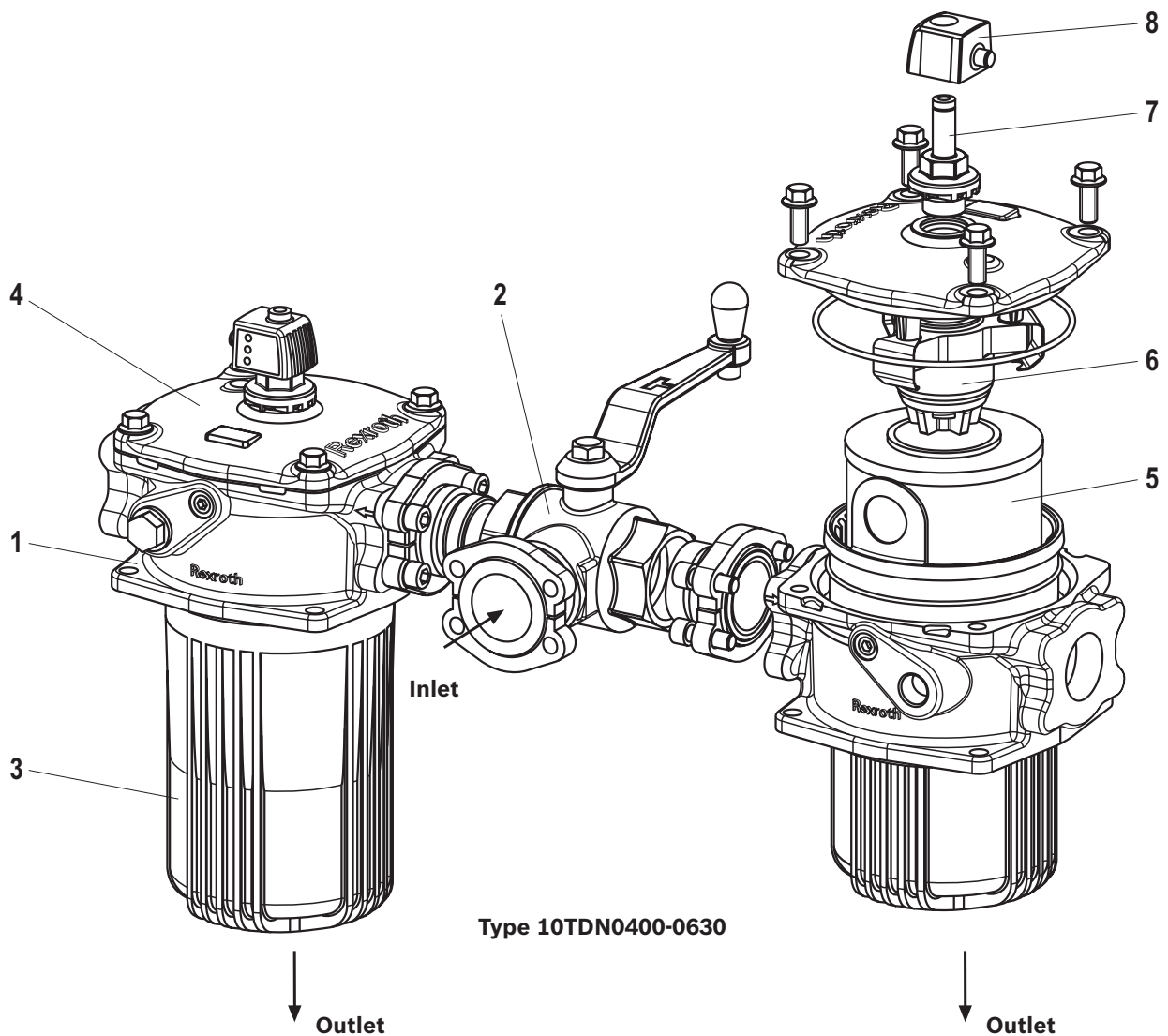

Technical data

(For applications outside these parameters please consult us!)

General						
Installation position	vertical					
Ambient temperature range	°C [°F]	-10...+65 [14...+149]				
Storage conditions	▶ NBR seal	°C [°F]	-40 ... +65 [-40... +149]; max. relative air humidity: 65%			
	▶ FKM seal	°C [°F]	-20 ... +65 [-4 ... +149]; max. relative air humidity: 65%			
Weight	Size	0040	0063	0100	0160	0250
	kg [lbs]	4.46 [9.81]	4.86 [10.7]	5.26 [11.6]	14 [30.8]	15 [33]
	Size	0400	0630	1000	2000	2500
	kg [lbs]	23 [50.6]	27 [59.4]	61 [134.2]	68 [149.9]	79 [174.1]
Material	▶ Filter cover	Carbon fiber reinforced plastic (sizes 0040...0100) Aluminum (sizes 0160...2500)				
	▶ Filter head	Aluminum				
	▶ Filter bowl	Carbon fiber reinforced plastic (sizes 0040...0630) Aluminized steel (sizes 1000...2500)				
	▶ Visual maintenance indicator	(P2.2)	Plastic PA6			
		(V...)	Aluminum			
	▶ Bypass valve	Plastic				
	▶ electronic switching element	Plastic PA6				
	▶ Manometer	Plastic				
▶ Seals	NBR / FKM					
Surface requirement	▶ roughness depth	R_z max.	µm	25 (10TDN0040-0100) and 6.3 ... 16 (from 10TDN0160)		
Tank opening	▶ Flatness	t_E max.	µm	0.3 ... 0.5 (10TDN0040-0100) and 0.2 (from 10TDN0160)		

Hydraulic						
Maximum operating pressure	bar [psi]	10 [145] When using a manometer, the maximum permissible operating pressure is reduced to 6 bar [87 psi].				
Hydraulic fluid temperature range	°C [°F]	-10...+100 [+14...+212]				
Minimum conductivity of the medium	pS/m	300				
Fatigue strength according to ISO 10771	Load cycles	> 10 ⁵ at max. operating pressure				
Type of pressure measurement of the maintenance indicator	Back pressure					
Assignment: Response pressure of the maintenance indicator / release pressure of the bypass valve	bar [psi]	Response pressure of the maintenance indicator			Release pressure of the bypass valve	
		Without maintenance indicator			3.5 ± 0.35 [50.8 ± 5.1]	
		with manometer				
		V0.8 ± 0.15 [11.6 ± 2.2]				
		V1.5 ± 0.2 [21.8 ± 2.9]				
		V2.2 ± 0.3 [31.9 ± 4.4]				
P2.2 +0.45/-0.25 [31.9 (+6.4/-3.6)]						
Filtration direction	From the outside to the inside					

Technical data

(For applications outside these parameters please consult us!)

electric (electronic switching element)				
Electrical connection	Round plug-in connection M12x1, 4-pole			Standard connection EN 175301-803
Version	WE1SP- M12x1	WE2SP- M12x1	WE2SPSU- M12x1	WE1SP- EN175301-803
Contact load, direct voltage	$A_{max.}$	1		
Voltage range	$V_{max.}$	150 (AC/DC)	10-30 (DC)	250 (AC)/200 (DC)
max. switching power with resistive load	W	20		70
Switching type	▶ 75% signal	–	Normally open contact	–
	▶ 100% signal	Changeover	Normally closed contact	Normally closed contact
	▶ 2SPSU		Signal interconnection at 30 °C [86 °F], Return switching at 20 °C [68 °F]	
Display via LEDs in the electronic switching element 2SP...		Stand-by (LED green); 75% switching point (LED yellow) 100% switching point (LED red)		
Protection class according to EN 60529 IP 65		IP 67		IP 65
Ambient temperature range	°C [°F]	-25...+85 [-13...+185]		
For direct voltage above 24 V, spark extinguishing is to be provided for protecting the switching contacts.				
Weight	kg [lbs]	0.1 [0.22]		

Filter element				
Fiberglass paper H..XL	Single-use element on the basis of inorganic fiber			
		Filtration ratio as per ISO 16889 up to $\Delta p = 5$ bar [72.5 psi]	Achievable oil cleanliness according to ISO 4406 (SAE-AS 4059)	
Particle separation	H20XL	$\beta_{20(c)} \geq 200$	19/16/12 ... 22/17/14	
	H10XL	$\beta_{10(c)} \geq 200$	17/14/10 ... 21/16/13	
	H6XL	$\beta_{6(c)} \geq 200$	15/12/10 ... 19/14/11	
	H3XL	$\beta_{5(c)} \geq 200$	13/10/8 ... 17/13/10	
Permissible pressure differential	▶ A00	bar [psi]	30 [435]	

For detailed information on Rexroth filter elements please refer to data sheet 51420.

Compatibility with permitted hydraulic fluids

Hydraulic fluid	Classification	Suitable sealing materials	Standards
Mineral oil	HLP	NBR	DIN 51524
Biodegradable	▶ Water insoluble	HETG	VDMA 24568
		HEES	
	▶ Water soluble	HEPG	VDMA 24568
Flame-resistant	▶ Water-free	HF DU, HF DR	VDMA 24317
	▶ Contains water	HF AS	DIN 24320
		HF AE	
		HF C	
		NBR	VDMA 24317



Important information on hydraulic fluids:

- ▶ For more information and data on the use of other hydraulic fluids, please refer to data sheet 90220 or contact us!
- ▶ **Flame-resistant, aqueous:** Due to possible chemical reactions with materials or machine and system component surface coating, the service life with these hydraulic fluids may be less than expected.

Filter materials made of filter paper (cellulose) may not be used, filter elements with glass fiber material have to be used instead.

- ▶ **Biodegradable:** If filter materials made of filter paper are used, the filter life may be shorter than expected due to material incompatibility and swelling.

Characteristic curves: H3XL

(measured with mineral oil HLP46 according to DIN 51524)

Spec. Weight: < 0.9 kg/dm³

Δp -Q characteristic curves for complete filter

recommended initial Δp for design = 0.5 bar [7.25 psi]

Selection of the perfect filter is made possible by our online "Bosch Rexroth FilterSelect" design software.

- 140 mm²/s [649 SUS]
- · - 68 mm²/s [315 SUS]
- - - 30 mm²/s [142 SUS]

Oil viscosity:

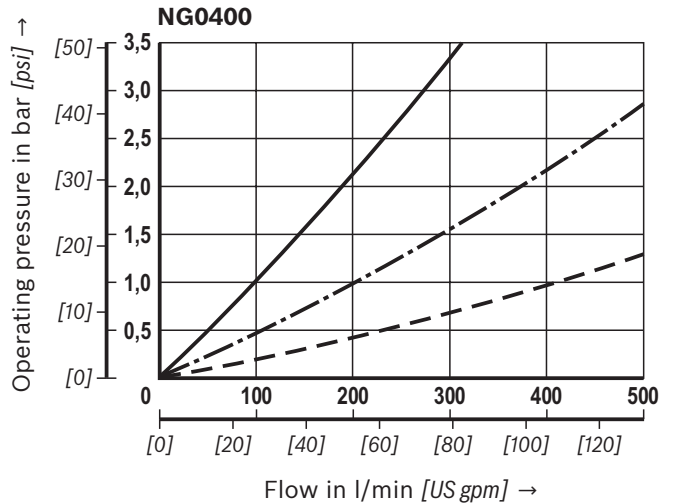
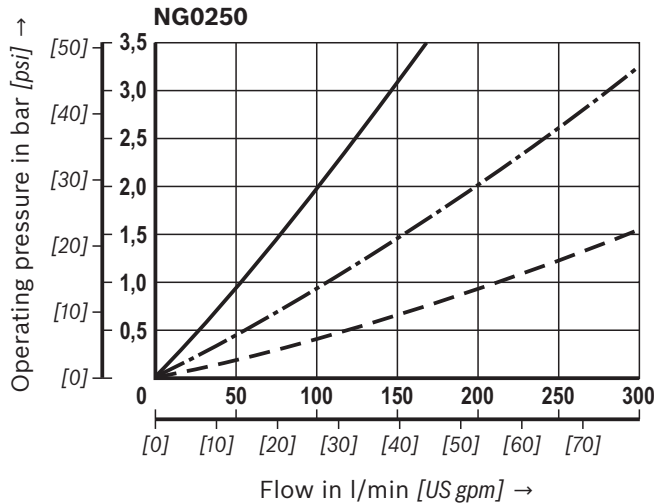
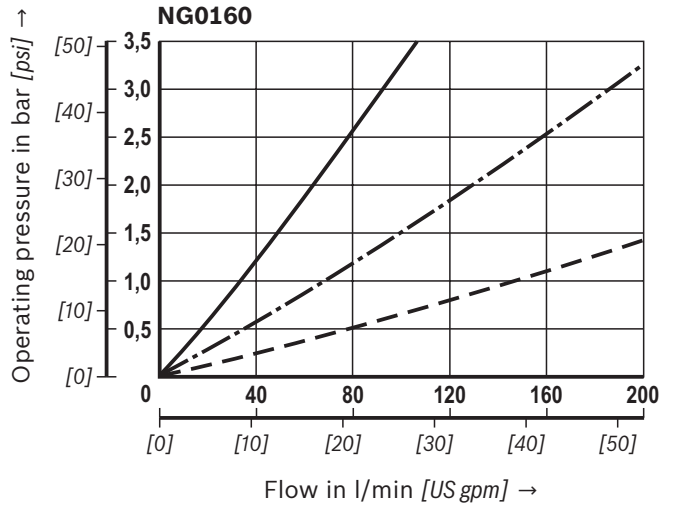
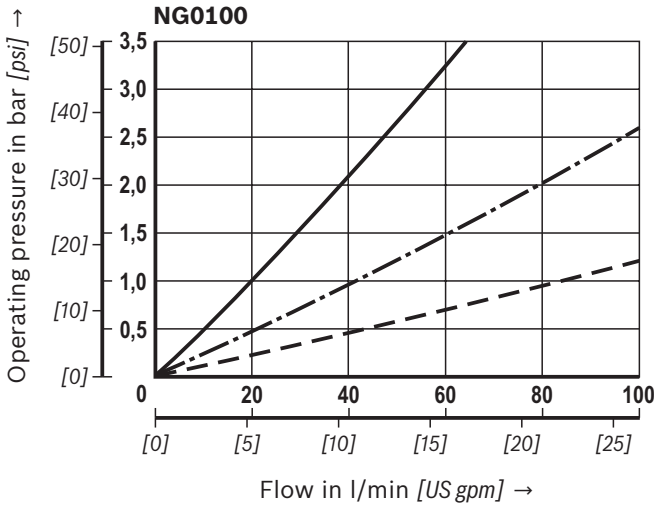
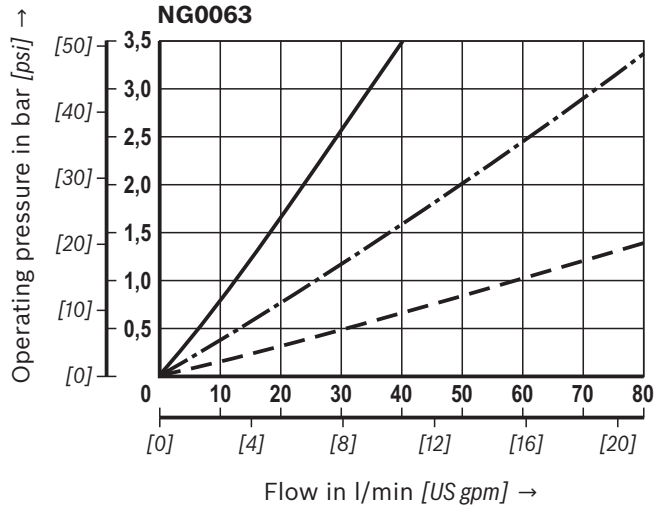
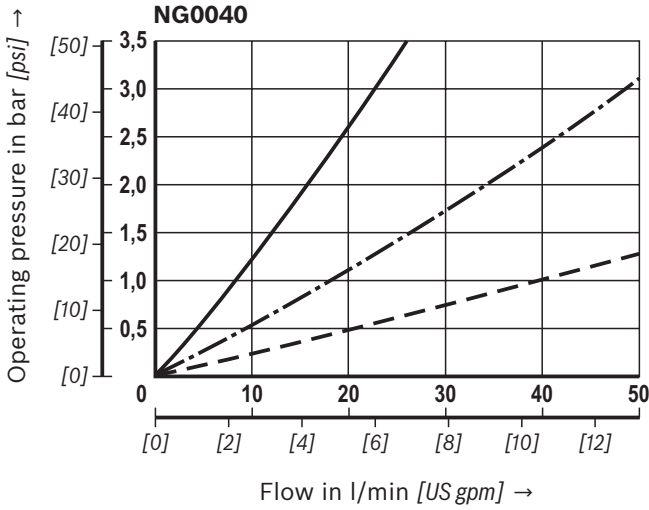

Characteristic curves: H3XL

(measured with mineral oil HLP46 according to DIN 51524)

Spec. Weight: < 0.9 kg/dm³

Δp -Q characteristic curves for complete filter

recommended initial Δp for design = 0.5 bar [7.25 psi]

Selection of the perfect filter is made possible by our online "Bosch Rexroth FilterSelect" design software.

Oil viscosity:

- 140 mm²/s [649 SUS]
- · - 68 mm²/s [315 SUS]
- - - 30 mm²/s [142 SUS]

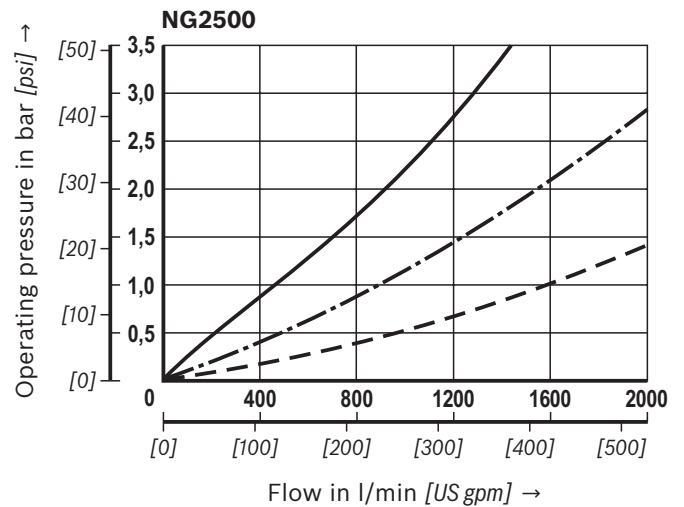
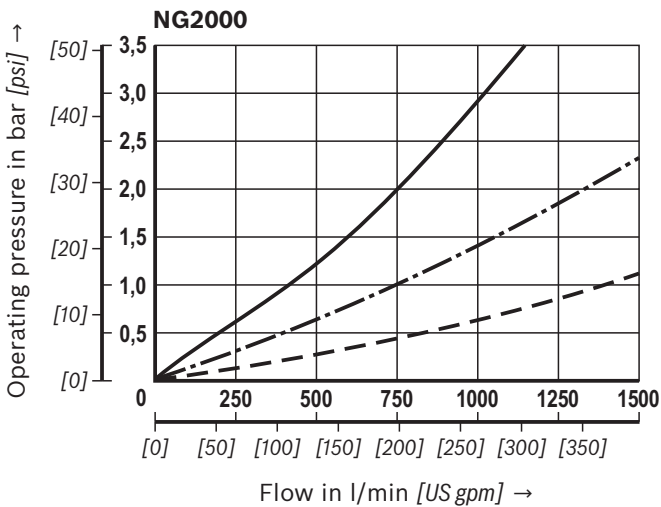
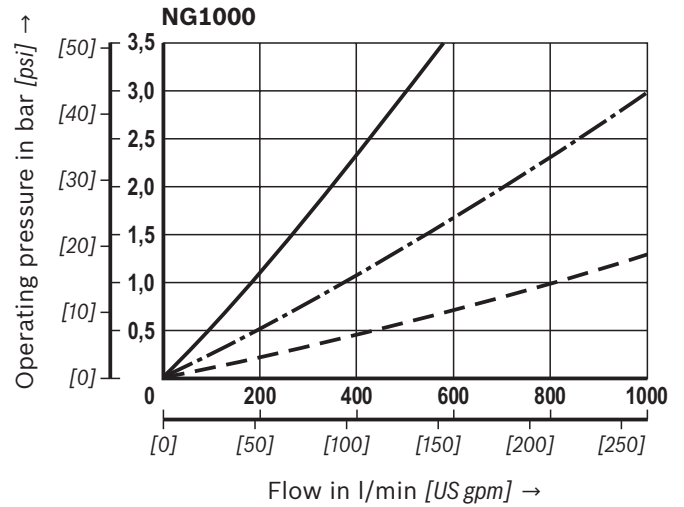
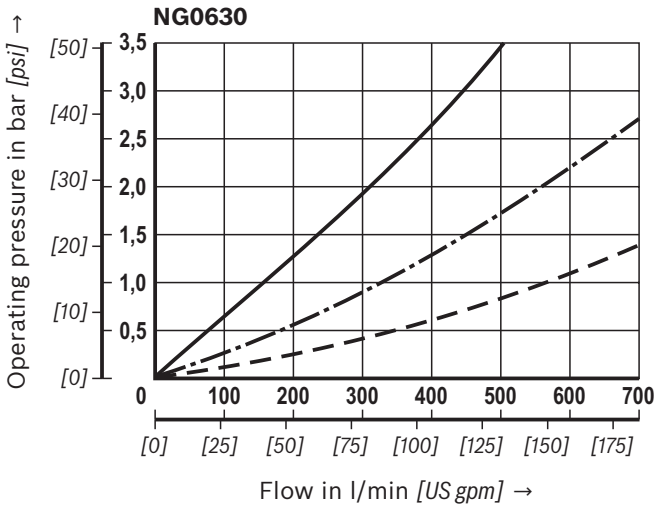

Characteristic curves: H6XL

(measured with mineral oil HLP46 according to DIN 51524)

Spec. Weight: < 0.9 kg/dm³

Δp -Q characteristic curves for complete filter

recommended initial Δp for design = 0.5 bar [7.25 psi]

Selection of the perfect filter is made possible by our online "Bosch Rexroth FilterSelect" design software.

Oil viscosity:

- 140 mm²/s [649 SUS]
- · - 68 mm²/s [315 SUS]
- - - 30 mm²/s [142 SUS]

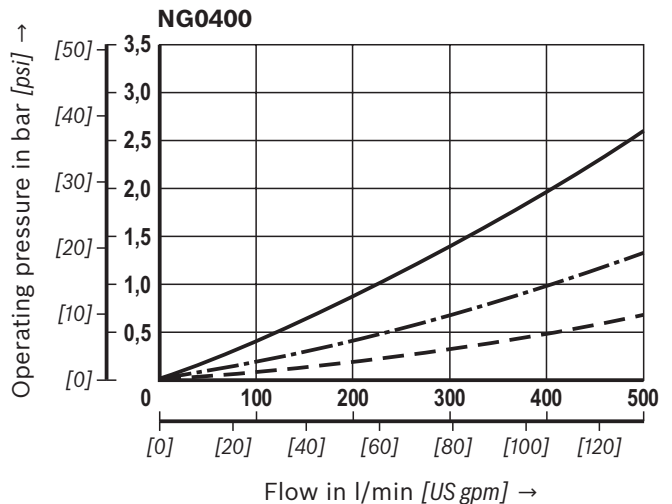
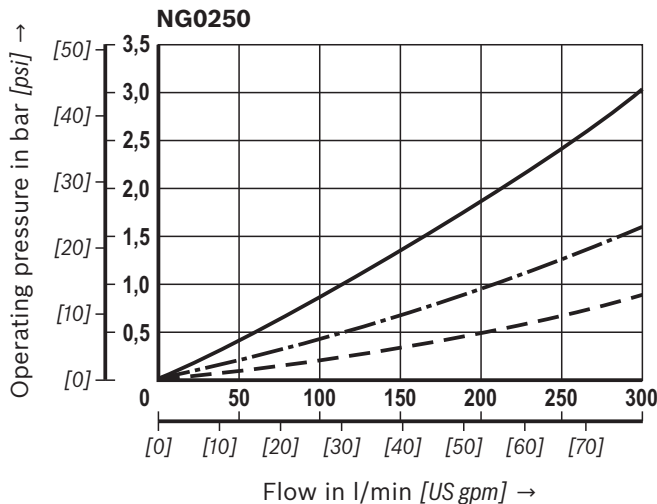
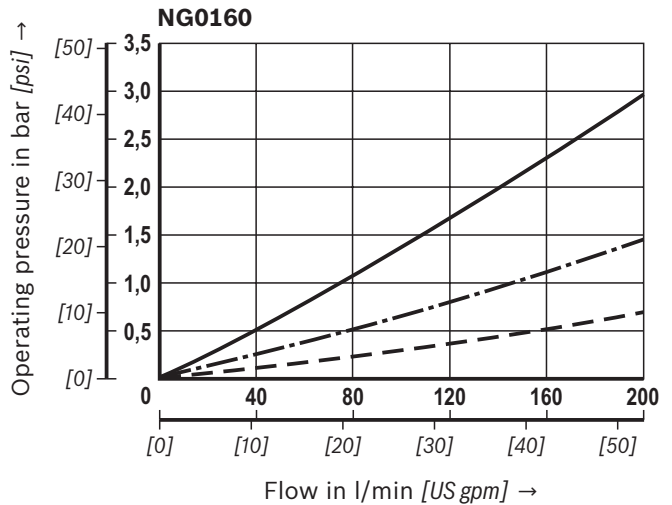
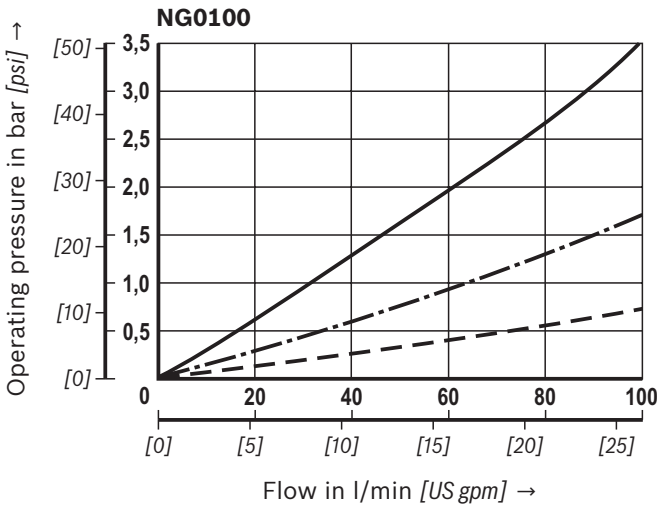
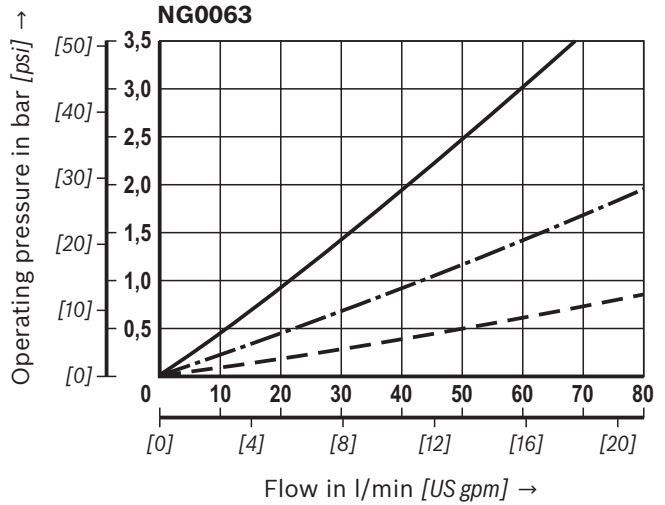
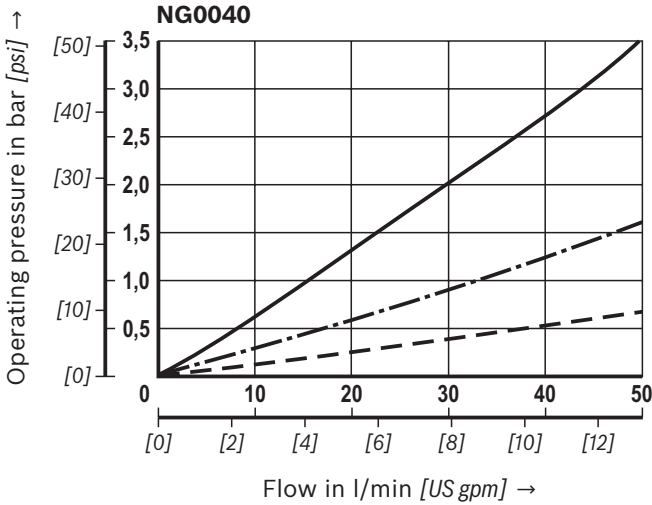

Characteristic curves: H6XL

(measured with mineral oil HLP46 according to DIN 51524)

Spec. Weight: < 0.9 kg/dm³

Δp -Q characteristic curves for complete filter

recommended initial Δp for design = 0.5 bar [7.25 psi]

Selection of the perfect filter is made possible by our online "Bosch Rexroth FilterSelect" design software.

Oil viscosity:

- 140 mm²/s [649 SUS]
- · - 68 mm²/s [315 SUS]
- - - 30 mm²/s [142 SUS]

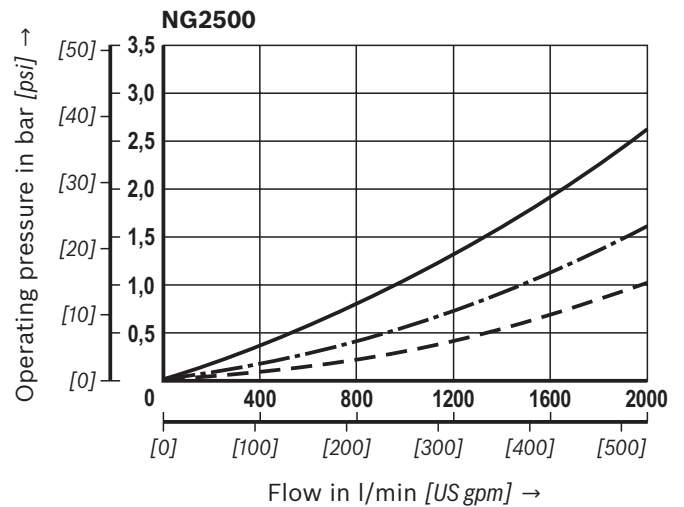
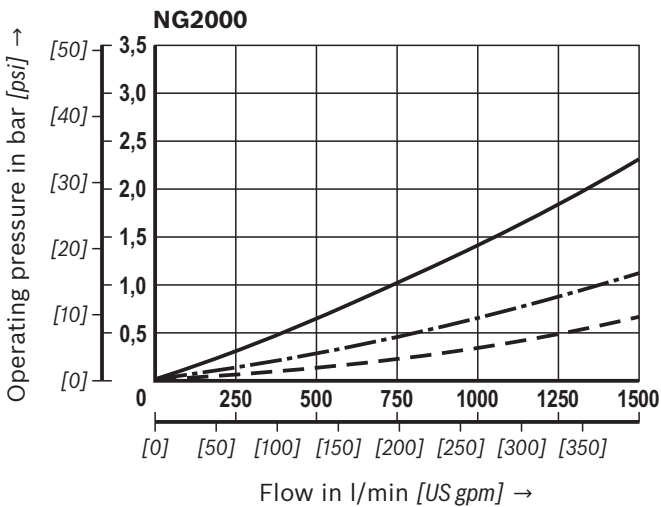
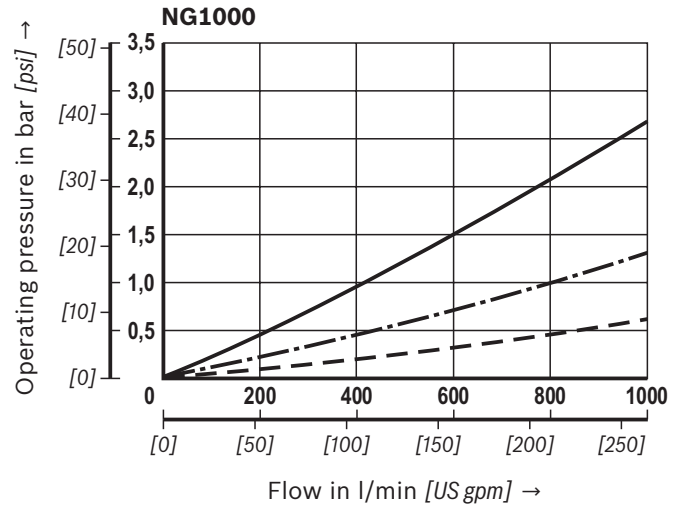
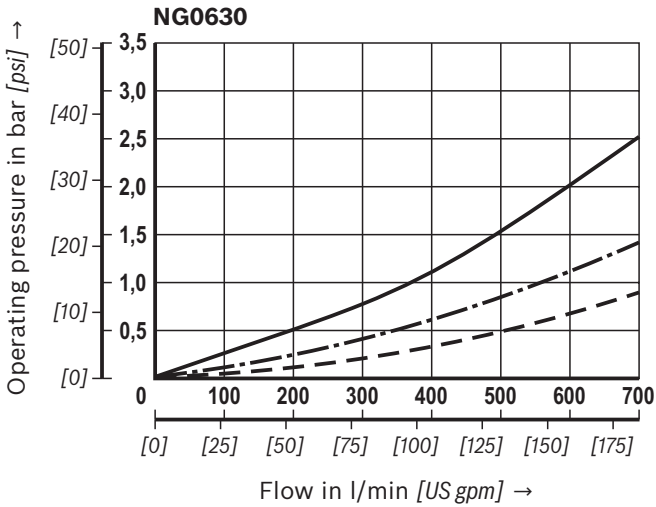

Characteristic curves: H10XL

(measured with mineral oil HLP46 according to DIN 51524)

Spec. Weight: < 0.9 kg/dm³

Δp -Q characteristic curves for complete filter

recommended initial Δp for design = 0.5 bar [7.25 psi]

Selection of the perfect filter is made possible by our online "Bosch Rexroth FilterSelect" design software.

Oil viscosity:

- 140 mm²/s [649 SUS]
- · - 68 mm²/s [315 SUS]
- - - 30 mm²/s [142 SUS]

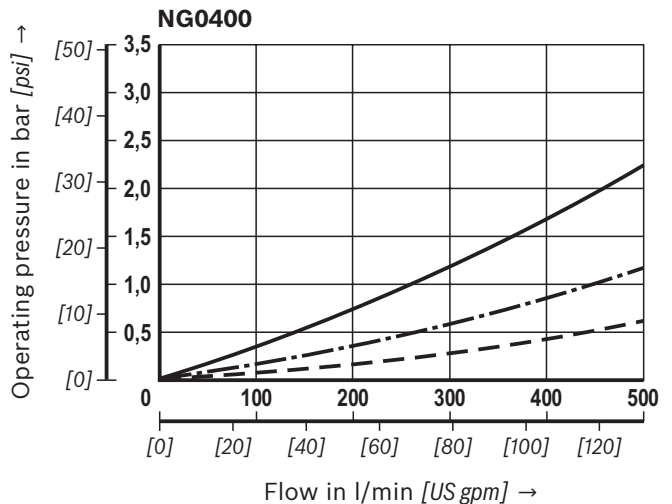
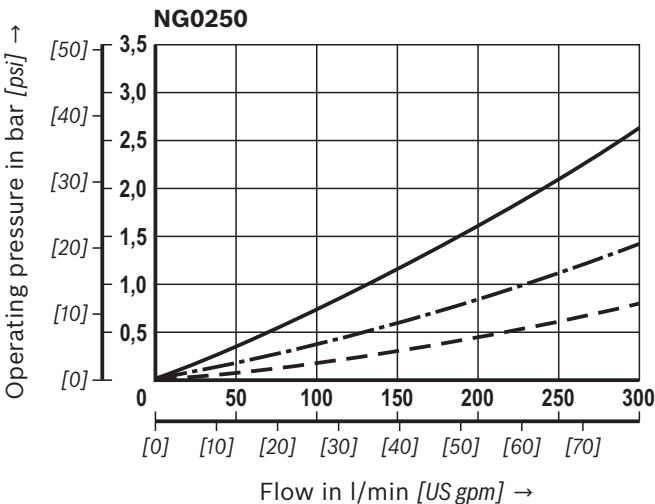
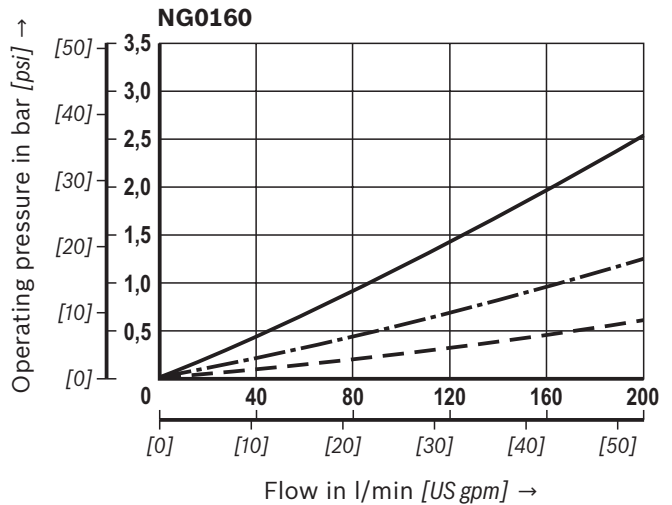
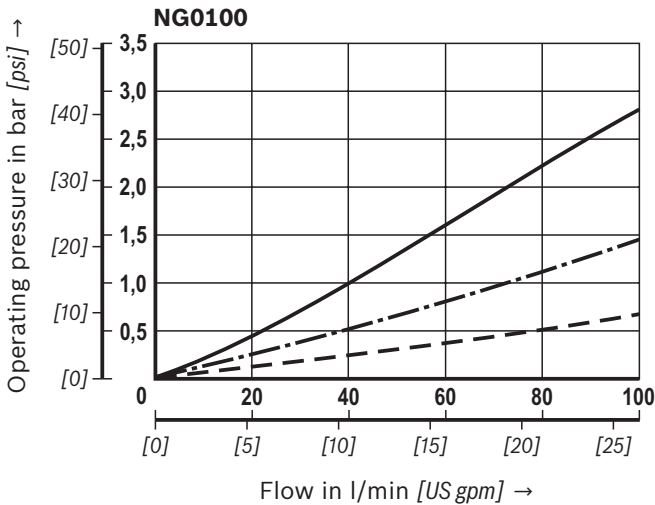
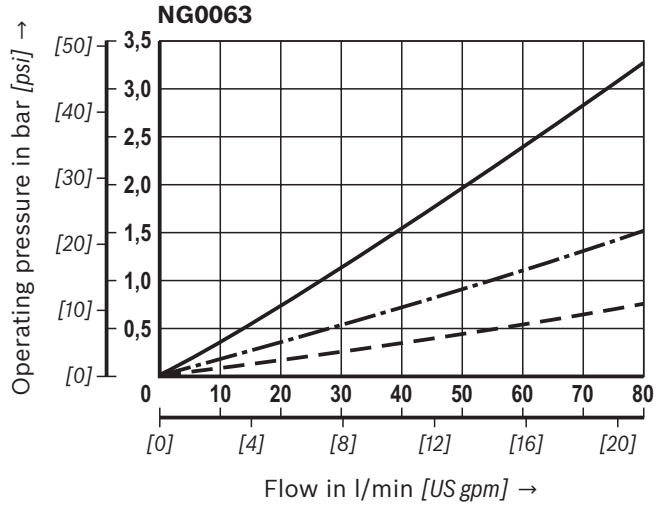
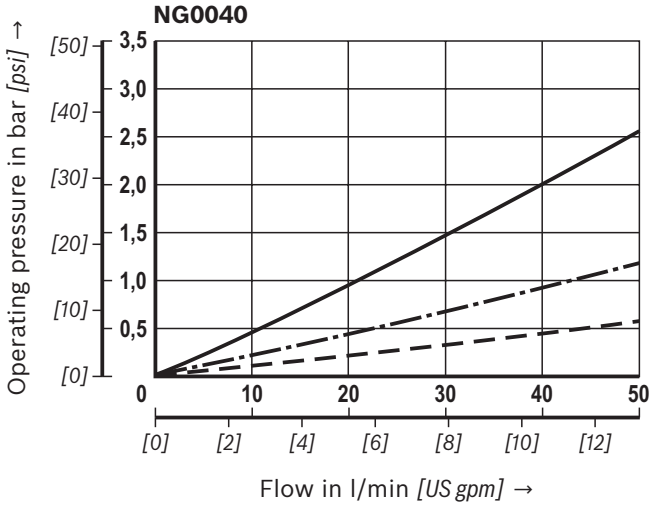

Characteristic curves: H10XL

(measured with mineral oil HLP46 according to DIN 51524)

Spec. Weight: < 0.9 kg/dm³

Δp -Q characteristic curves for complete filter

recommended initial Δp for design = 0.5 bar [7.25 psi]

Selection of the perfect filter is made possible by our online "Bosch Rexroth FilterSelect" design software.

Oil viscosity:

- 140 mm²/s [649 SUS]
- · - 68 mm²/s [315 SUS]
- - - 30 mm²/s [142 SUS]

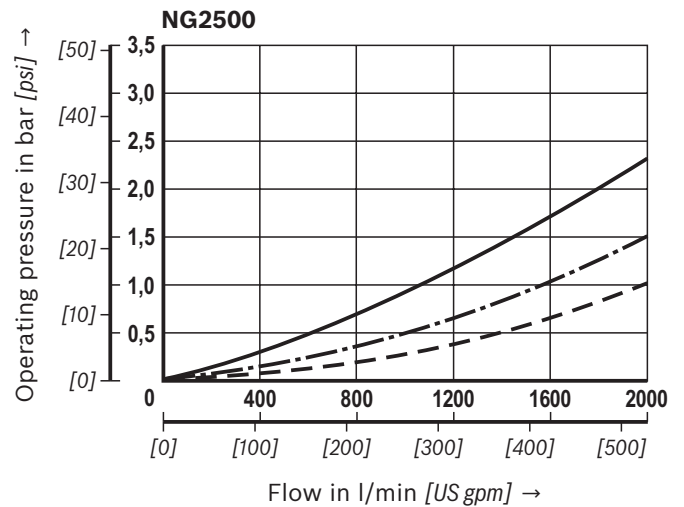
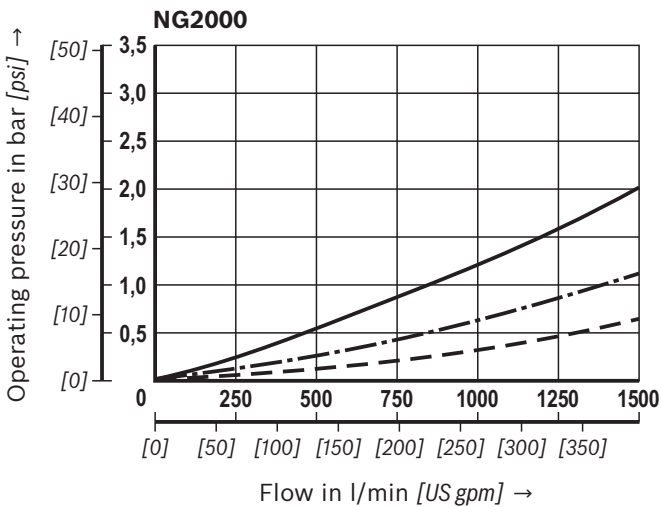
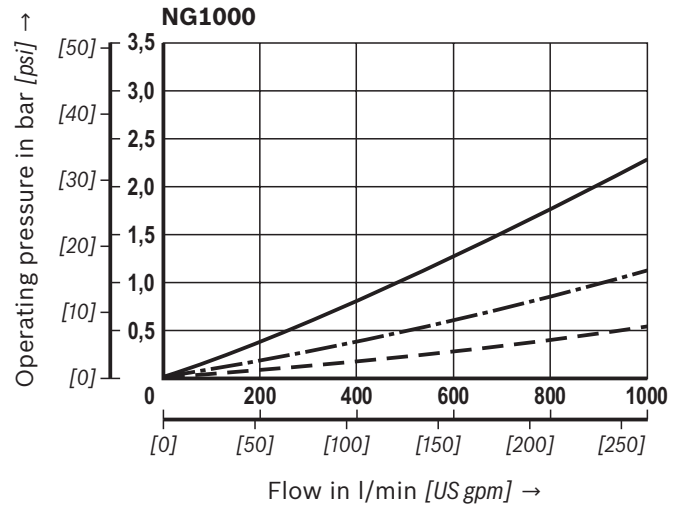
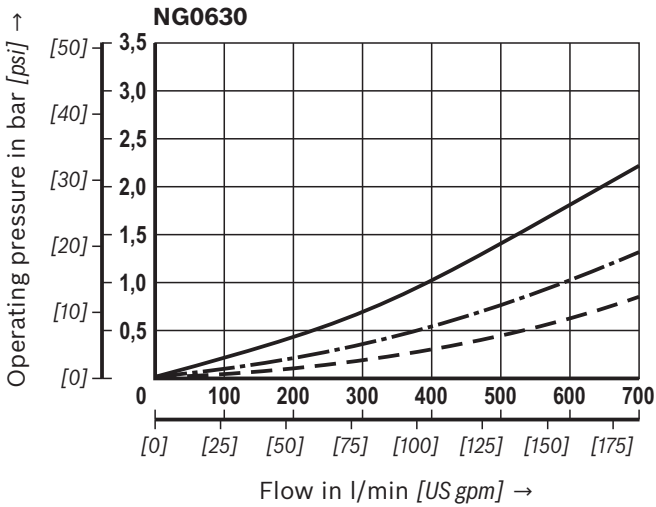

Characteristic curves: H20XL

(measured with mineral oil HLP46 according to DIN 51524)

Spec. Weight: < 0.9 kg/dm³

Δp -Q characteristic curves for complete filter

recommended initial Δp for design = 0.5 bar [7.25 psi]

Selection of the perfect filter is made possible by our online "Bosch Rexroth FilterSelect" design software.

Oil viscosity:

- 140 mm²/s [649 SUS]
- · - 68 mm²/s [315 SUS]
- - - 30 mm²/s [142 SUS]

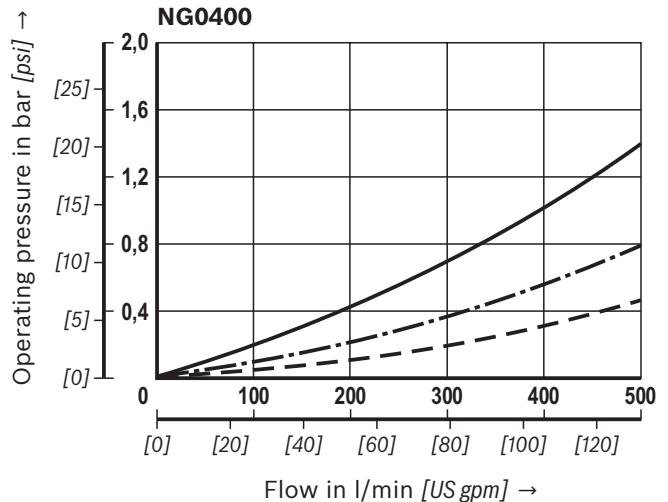
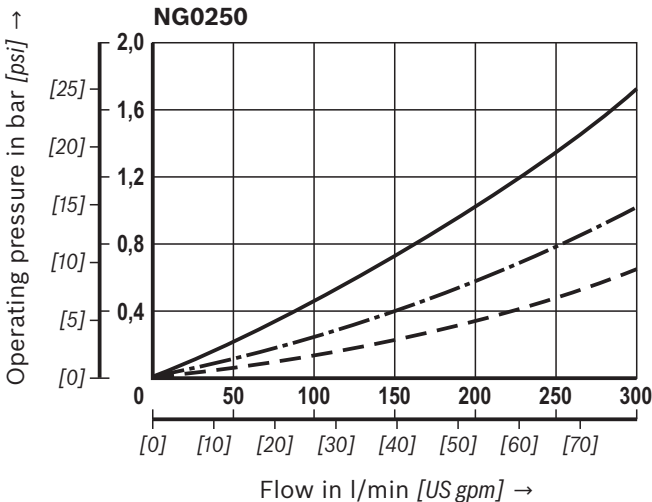
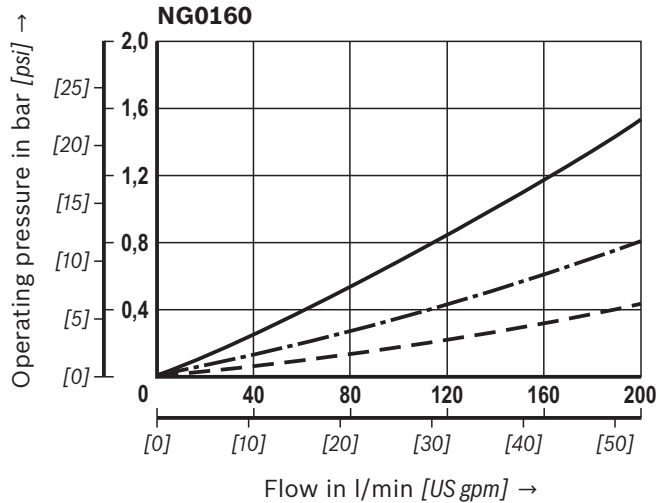
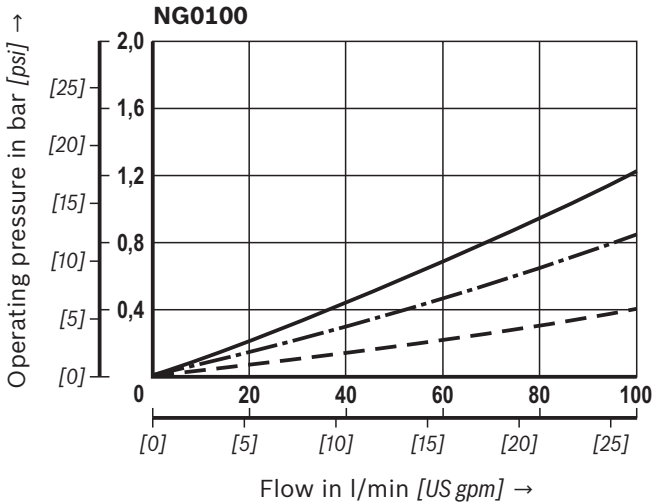
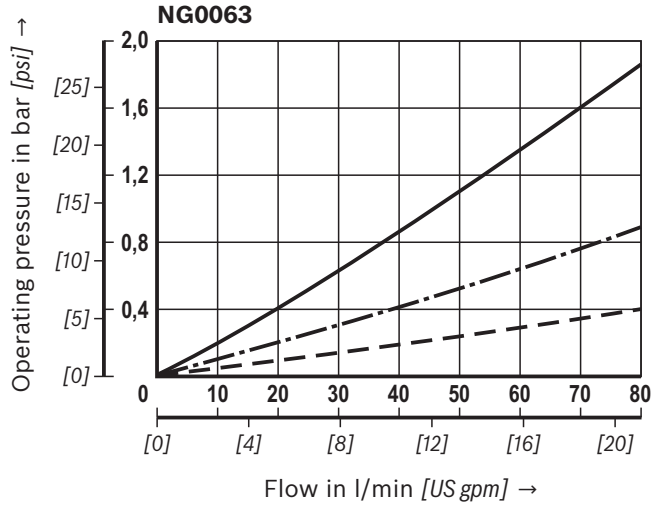
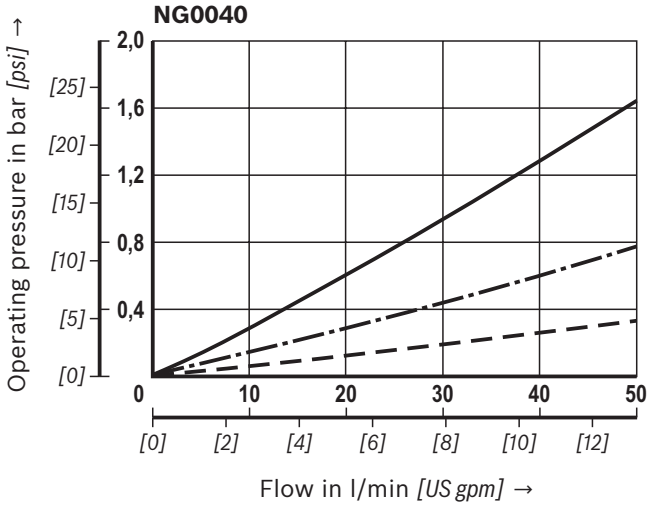

Characteristic curves: H20XL

(measured with mineral oil HLP46 according to DIN 51524)

Spec. Weight: < 0.9 kg/dm³

Δp -Q characteristic curves for complete filter

recommended initial Δp for design = 0.5 bar [7.25 psi]

Selection of the perfect filter is made possible by our online "Bosch Rexroth FilterSelect" design software.

Oil viscosity:

- 140 mm²/s [649 SUS]
- · - 68 mm²/s [315 SUS]
- - - 30 mm²/s [142 SUS]

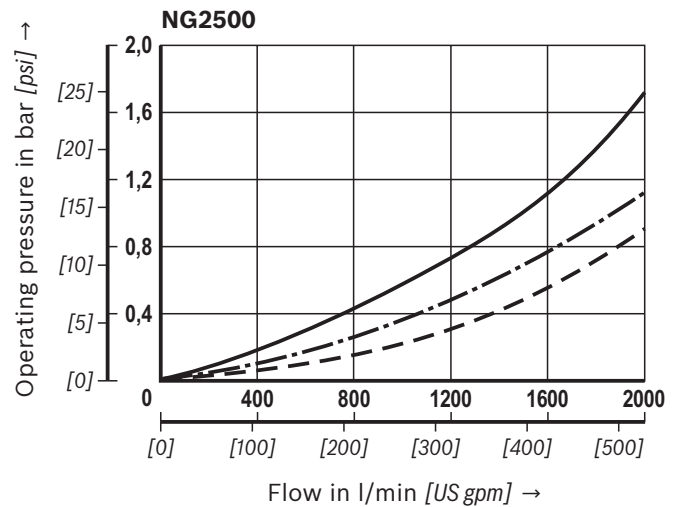
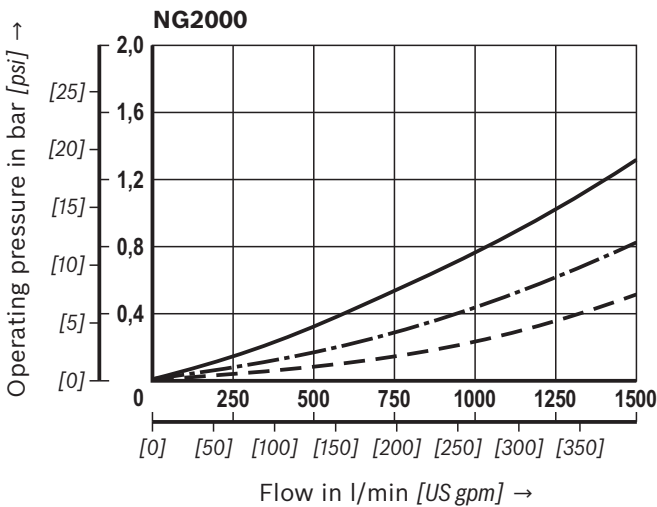
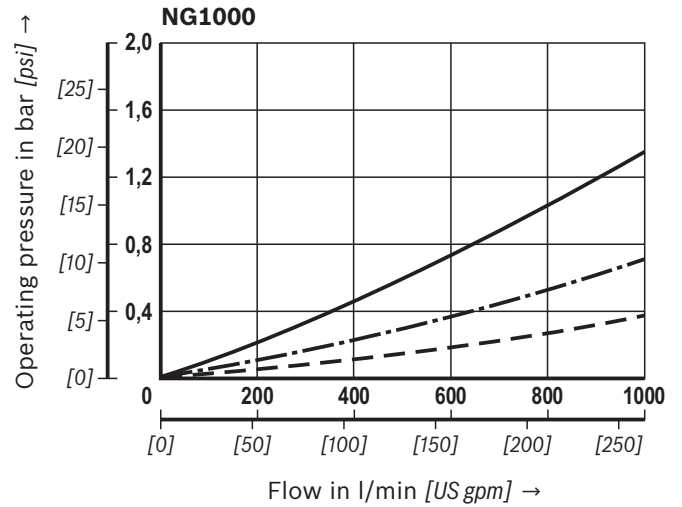
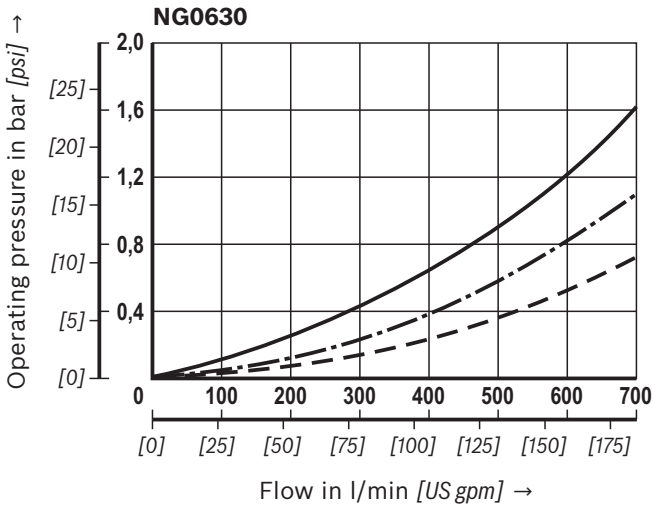

Dimensions: 10TDN0040, 0063, 0100
(dimensions in mm [inch])

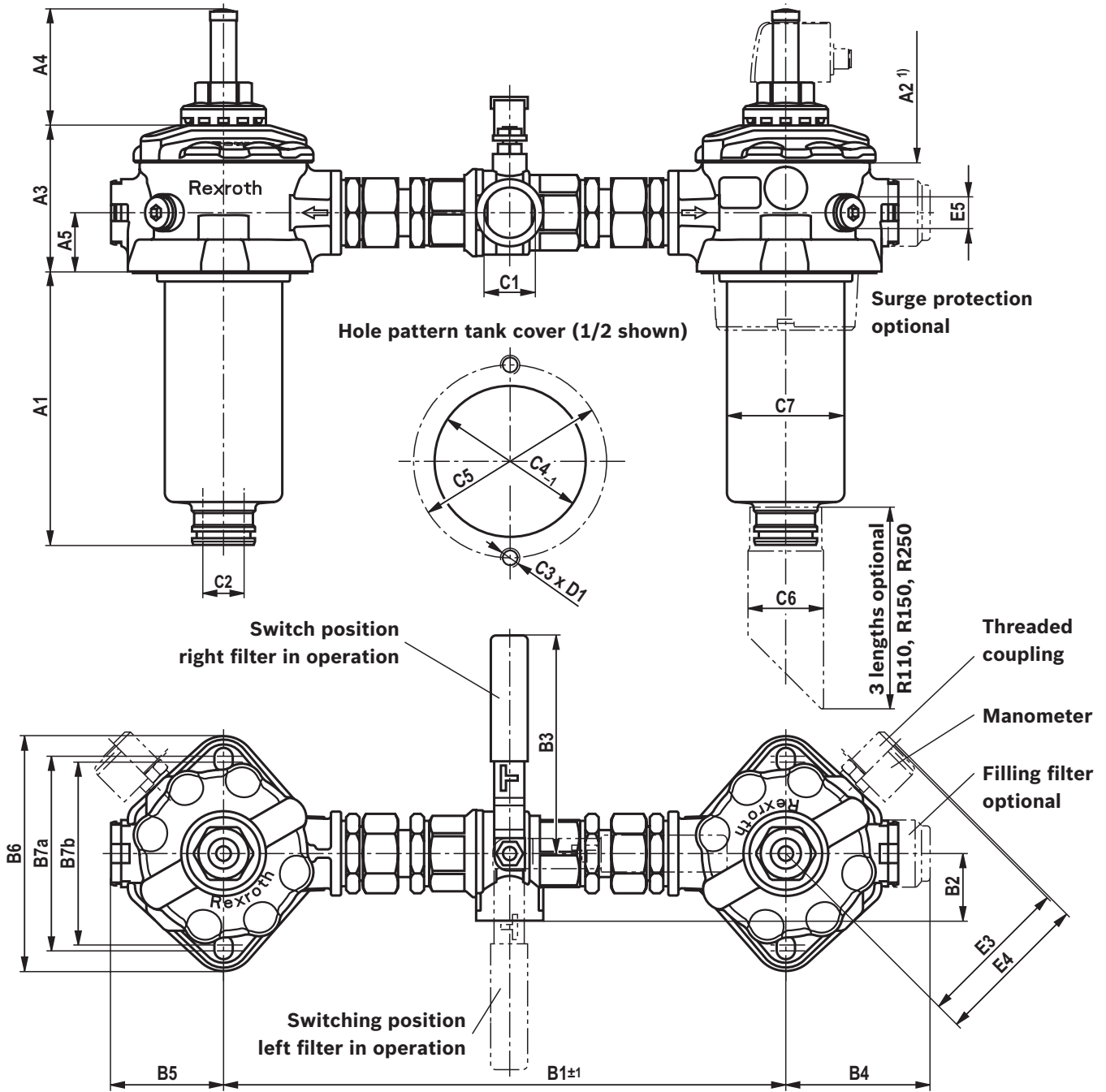

¹⁾ Observe the servicing height plus the length of the outlet pipe, if applicable

Type	Height					Depths							
	A1	A2 ¹⁾	A3	A4	A5	B1	B2	B3	B4	B5	B6	B7a	B7b
10TDN0040	103 [4.06]	100 [3.94]	87 [3.43]	69 [2.72]	35 [1.38]	335 [13.19]	45 [1.77]	130 [5.12]	86 [3.39]	67 [2.64]	140 [5.51]	116 [4.57]	109 [4.29]
10TDN0063	163 [6.42]	160 [6.30]											
10TDN0100	253 [9.96]	250 [9.84]											

Type	Connections						Depths D1	Measuring port				
	C1 connection		ØC2	C3	ØC4	ØC5		C6	ØC7	E3	E4	E5
	Standard	U... (SAE J1926)										
10TDN0040	G1	SAE 16 1 5/16-12 UN-2B	25 [0.98]	M10	90 [3.54]	115 [4.53]	45 [1.77]	71 [2.80]	12 ⁺² [0.47 ^{+0.08}]	86 [3.39]	90 [3.54]	G1/4
10TDN0063												
10TDN0100												

Dimensions: 10TDN0160, 0250
(dimensions in mm [inch])

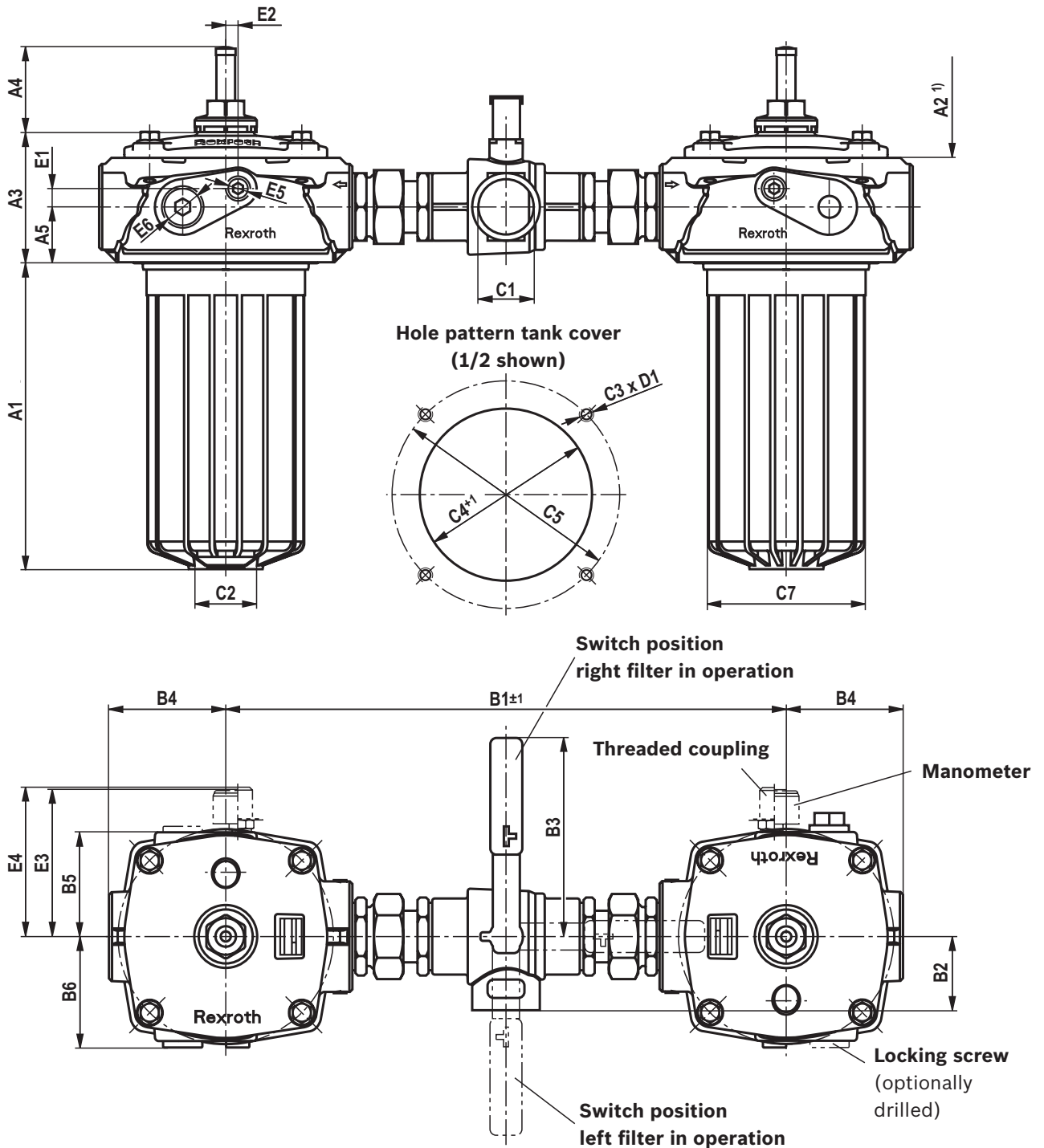

1) Observe the servicing height plus the length of the outlet pipe, if applicable

Type	Height					Depths					
	A1	A2 1)	A3	A4	A5	B1	B2	B3	B4	B5	B6
10TDN0160	160 [6.30]	160 [6.30]	106	69	45	456	60	159	95	85	90
10TDN0250	250 [9.84]	250 [9.84]	[4.17]	[2.72]	[1.77]	[17.95]	[2.36]	[6.26]	[3.74]	[3.35]	[3.54]

Type	Connections						Depths	Measuring port						
	C1 connection		ØC2	C3	ØC4	ØC5		ØC7	D1	E1	E2	E3	E4	E5
	Standard	U... (SAE J1926)												
10TDN0160	G1 1/2	SAE 20	G1 1/2	M10	140	185	129	12 ⁺²	15	10	116	120	G1/4	G3/4
10TDN0250		1 5/8-12 UN-2B			[5.51]	[7.28]	[5.08]	[0.47 ^{+0.08}]	[0.59]	[0.39]	[4.57]	[4.72]		

Dimensions: 10TDN0400, 0630
(dimensions in mm [inch])

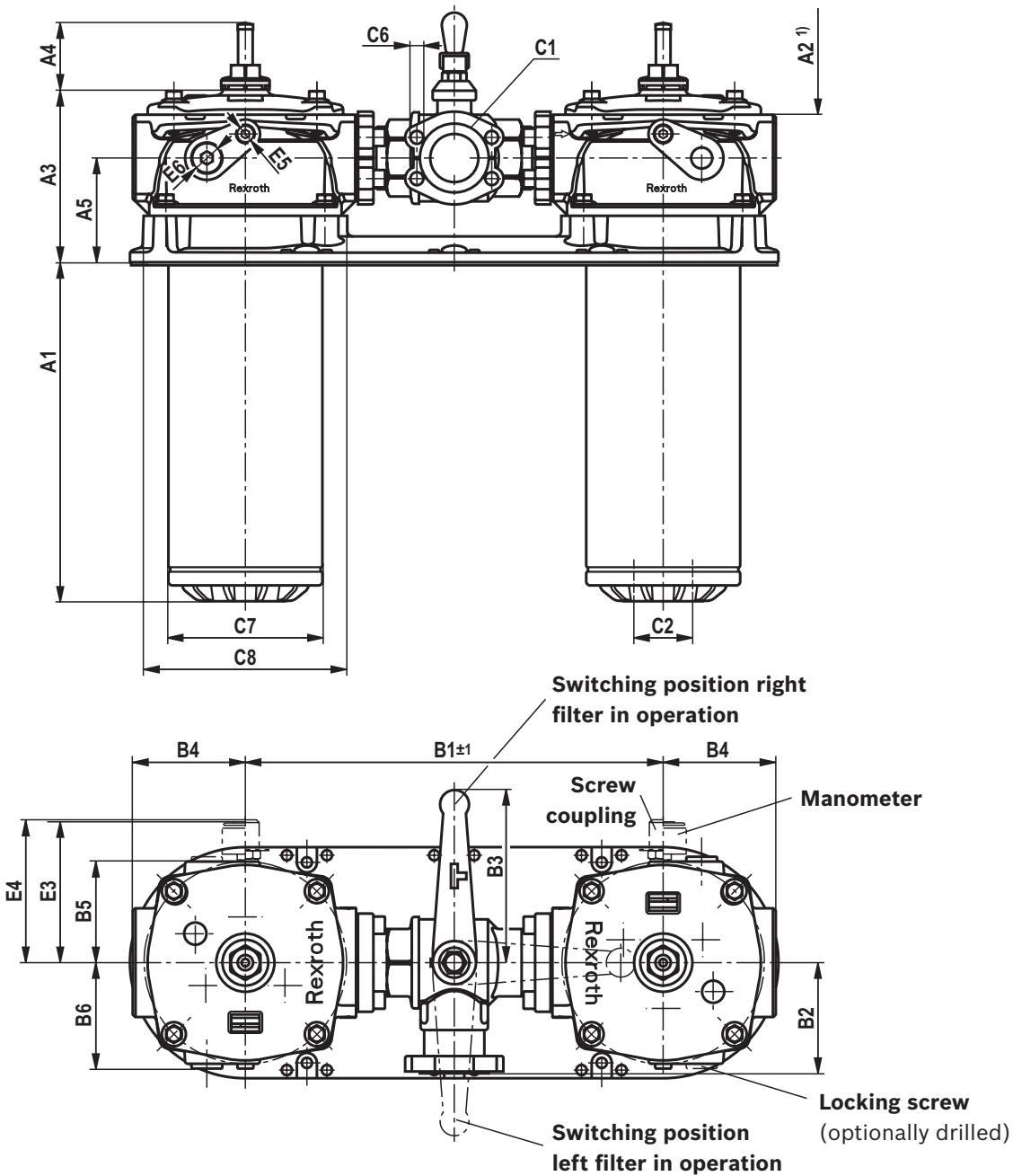

Hole pattern tank cover with installation plate

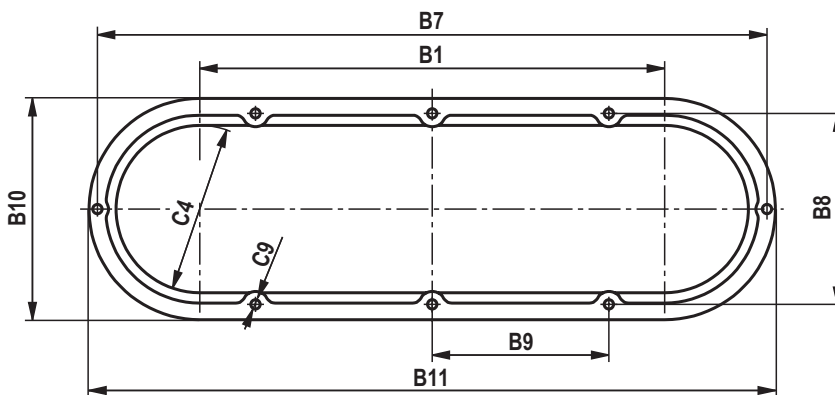

Hole pattern tank cover (1/2 shown) without installation plate

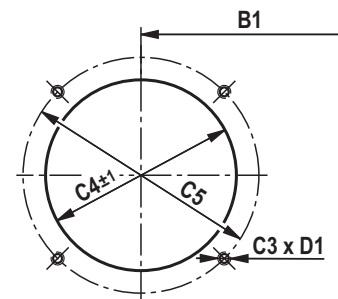

Dimensions: 10TDN0400, 0630

(dimensions in mm [inch])

Type	Height				
	A1	A2 ¹⁾	A3	A4	A5
10TDN0400	255 [10.04]	335 [13.19]	176 [6.93]	69 [2.72]	105 [4.13]
10TDN0630	352 [13.86]	485 [19.09]			

Type	Depths										
	B1	B2	B3	B4	B5	B6	B7	B8	B9	B10	B11
10TDN0400	500	143	220	117	105	110	720	205	190	238	738
10TDN0630	[19.69]	[5.63]	[8.66]	[4.61]	[4.13]	[4.33]	[28.35]	[8.07]	[7.48]	[9.37]	[29.06]

Type	Connections										
	C1 connection		C2	C3	ØC4	ØC5	C6	ØC7	ØC8	C9	
	Standard	U... (SAE J1926)									
10TDN0400	SAE 2 1/2"	-	G2	M10	178 [70.1]	220 [8.66]	M12	160 [6.30]	202 [7.95]	M10	
10TDN0630	3000 psi										

Type	Depths	Measuring port				
	D1	E1	E3	E4	E5	E6
10TDN0400	12 ⁺² [0.47 ^{+0.08}]	25 [0.98]	134 [5.28]	138 [5.43]	G1/4	G3/4
10TDN0630						

¹⁾ Observe the servicing height plus the length of the outlet pipe, if applicable

Dimensions: 10TDN1000, 10TD2000, 10TD2500
 (dimensions in mm [inch])

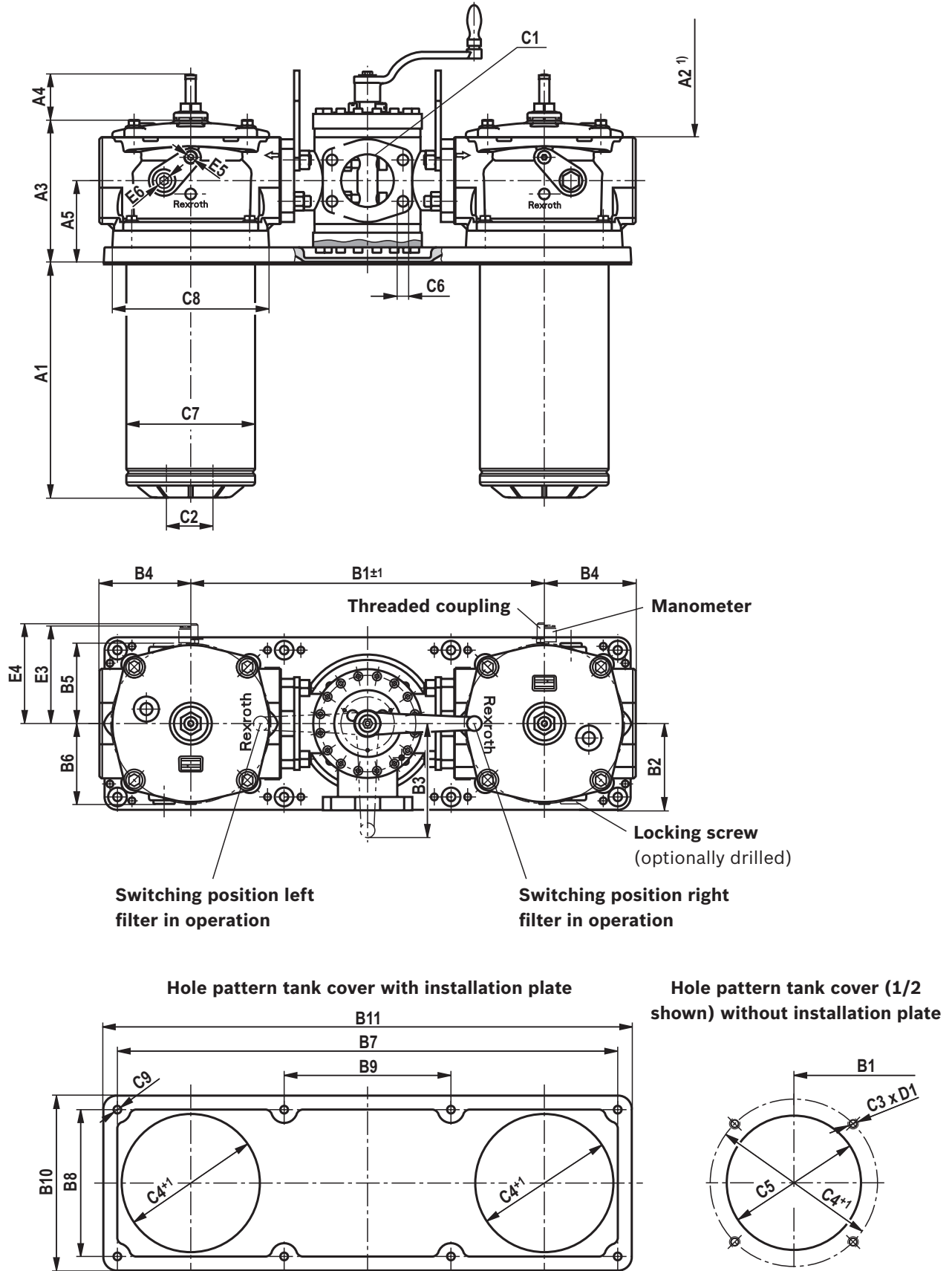

Dimensions: 10TDN1000, 10TD2000, 10TD2500

(dimensions in mm [inch])

Type	Height				
	A1	A2 ¹⁾	A3	A4	A5
10TDN1000	353 [13.90]	530 [20.87]	213 [8.39]	69 [2.72]	123 [4.84]
10TD2000	710 [27.95]	880 [34.65]			
10TD2500	945 [37.20]	1130 [44.49]			

Type	Depths										
	B1	B2	B3	B4	B5	B6	B7	B8	B9	B10	B11
10TDN1000	530 [20.87]	130 [5.12]	160 [6.30]	137 [5.39]	115 [4.53]	120 [4.72]	750 [29.53]	220 [8.66]	250 [9.84]	262 [10.31]	792 [31.18]
10TD2000											
10TD2500											

Type	Connections									
	C1 connection		C2	C3	ØC4	ØC5	C6	ØC7	ØC8	C9
	Standard	U... (SAE J1926)								
10TDN1000	SAE 3" 3000 psi	-	G3	M10	202 [7.95]	250 [9.84]	M16	193 [7.60]	235 [9.25]	M10
10TD2000										
10TD2500										

Type	Measuring port					
	Depths	E1	E3	E4	E5	E6
	D1					
10TDN1000	12 ⁺² [0.47 ^{+0.08}]	35 [1.38]	145 [5.71]	149 [5.87]	G1/4	G3/4
10TD2000						
10TD2500						

¹⁾ Observe the servicing height plus the length of the outlet pipe, if applicable

Dimensions: Maintenance indicator
(dimensions in mm [inch])

**electronic switching element
with round plug-in connection M12x1, 4-pole**

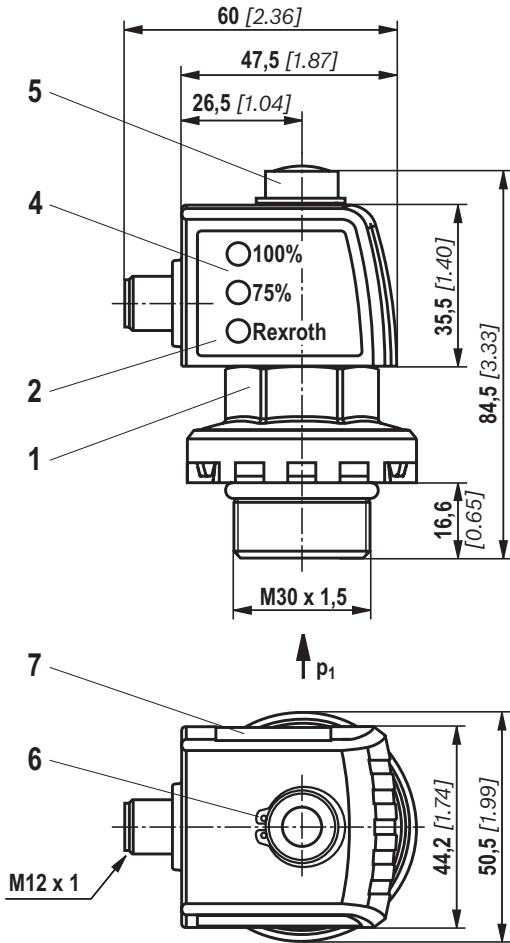

**electronic switching element
with rectangular plug-in connection EN 175301-803**

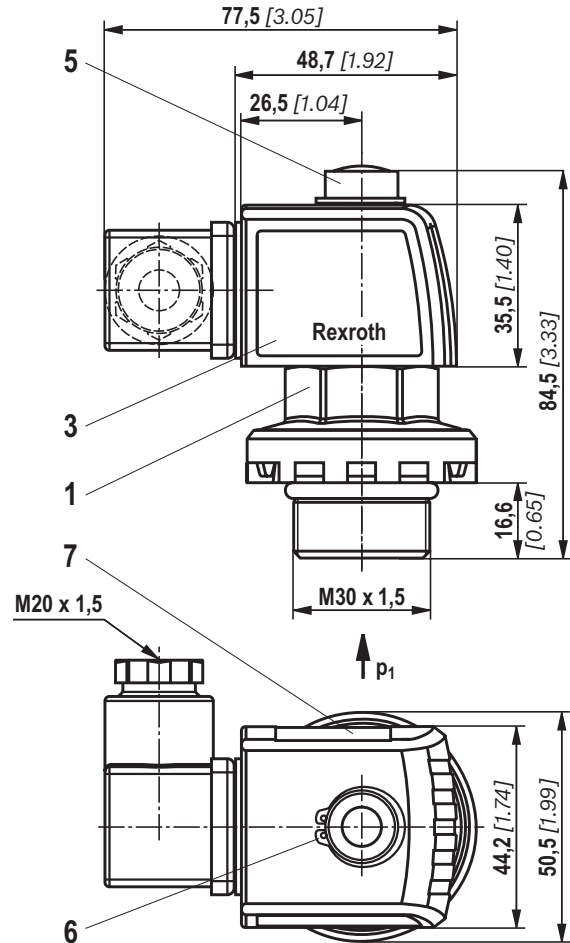

- 1 Mechanical optical maintenance indicator;
max. tightening torque $M_{A \max} = 50 \text{ Nm}$ [36.88 lb-ft]
Tightening torque for back pressure indicator in PA6.6
 $M_{A \max} = 35 \text{ Nm}$ [25.82 lb-ft]
- 2 Switching element with locking ring for electrical maintenance indicator (rotatable by 360°); plug-in connection M12x1, 4-pole
- 3 Switching element with locking ring for electrical maintenance indicator (rotatable by 360°); plug-in connection EN175301-803
- 4 Housing with three LEDs: 24 V =
green: Stand-by
yellow: Switching point 75%
red: Switching point 100%
- 5 Optical display with memory function
- 6 Locking ring DIN 471-16x1, material no. **R900003923**
- 7 Name plate

Important:

If an electronic switching element with signal suppression up to 30 °C [86 °F] is used (WE-2SPSU-M12X1, **R928028411**), it has to be ensured that the aluminum version of the mechanical-optical maintenance indicator **must** be used. These maintenance indicators are referred to in the filter type key as “V2.2”, “V1.5” or “V0.8”. Also refer to the chapter “Spare parts and accessories”. The temperature-controlled signal processing does not work with mechanical-optical maintenance indicators made of polyamide.

Ordering code spare parts

Filter element

01	02	03	04	05	06
1			- A00	- 0	-

01	Design	1
----	--------	---

Size

02	TDN... (Filter element according to DIN 24550)	0040 0063 0100 0160 0250 0400 0630 1000
	TD... (Filter elements according to Bosch Rexroth standard)	2000 2500

Filter rating in μm

03	Nominal	Paper, not cleanable	P10 P25
	Nominal	Stainless steel wire mesh, cleanable	G10 G25 G40 G60 G100
	Absolute (ISO 16889; $\beta_x(c) \geq 200$)	Glass fiber material, not cleanable	H3XL H6XL H10XL H20XL
	Absolute (ISO 16889; $\beta_x(c) \geq 200$)	Water-absorbing, not cleanable	AS6 AS10 AS20

Pressure differential

04	Max. admissible filter element pressure differential: 30 bar [435 psi], filter with bypass valve	A00
----	---------------------------------------------------------------------------------------------------------	-----

Bypass valve

05	without bypass valve	0
----	-----------------------------	---

Seal

06	NBR seal	M
	FKM seal	V

Order example:

1.0040 H10XL-A00-0-M

Material no. R928005837

Further models on request.

For detailed information on Rexroth filter elements please refer to data sheet 51420.

Ordering code spare parts

Filter element

Preferred program replacement elements

Filter element type	Filter material/material no.			
	H3XL	H6XL	H10XL	H20XL
1.0040 ...A00-0-M	R928005835	R928005836	R928005837	R928005838
1.0063 ...A00-0-M	R928005853	R928005854	R928005855	R928005856
1.0100 ...A00-0-M	R928005871	R928005872	R928005873	R928005874
1.0160 ...A00-0-M	R928005889	R928005890	R928005891	R928005892
1.0250 ...A00-0-M	R928005925	R928005926	R928005927	R928005928
1.0400 ...A00-0-M	R928005961	R928005962	R928005963	R928005964
1.0630 ...A00-0-M	R928005997	R928005998	R928005999	R928006000
1.1000 ...A00-0-M	R928006033	R928006034	R928006035	R928006036
1.2000 ...A00-0-M	R928041312	R928048158	R928040797	R928041313
1.2500 ...A00-0-M	R928041314	R928046806	R928040800	R928041315

Ordering code spare parts

Mechanical optical maintenance indicator

01	02	03	04	05	06	07
W	O	-	S01	-	-	10

01	Maintenance indicator	W
----	-----------------------	---

02	mechanical visual indicator	O
----	-----------------------------	---

Version

03	Back pressure M30x1.5	S01
----	-----------------------	-----

Switching pressure

04	0.8 bar [12 psi] (not possible with plastic version)	0.8
	1.5 bar [22 psi] (not possible with plastic version)	1.5
	2.2 bar [32 psi]	2.2

Seal

05	NBR seal	M
	FKM seal	V

Max. operating pressure

06	10 bar [145 psi]	10
----	------------------	----

Housing material

07	Plastic only 2.2 bar [32 psi] possible	PA
	Aluminum	No code

Mechanical optical maintenance indicator

Material no.	Description
R928038773	WO-S01-0.8-M-10
R928038772	WO-S01-0.8-V-10
R928038776	WO-S01-1.5-M-10
R928038774	WO-S01-1.5-V-10
R901025310	WO-S01-2.2-M-10
R901066232	WO-S01-2.2-V-10
R928038771	WO-S01-2.2-M-10-PA
R928038769	WO-S01-2.2-V-10-PA

Manometer ¹⁾

Material no.	Description
R928019224	M010 0-6 bar [0-87 psi], Fluid connection R 1/4, Ø 50 mm

¹⁾ When using a manometer, the maximum permissible operating pressure is reduced to 6 bar [87 psi].

Breathing filter element

(only for 10TDN0040-0100) incl. plastic cap

Material no.	Description
R928019705	71.001 P5-S00-0-0

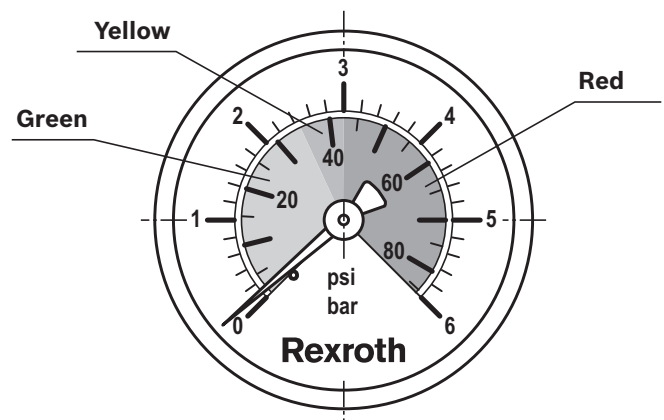

Ordering code spare parts

Seal kit

01	02	03	04	05	06
D	10TD		-	1X	/ - -

01	Seal kit	D
----	----------	----------

02	Series	10TD
----	--------	-------------

Size

03	0040-0100	N0040-0100
	0160-0250	N0160-0250
	0400-0630	N0400-0630
	1000	N1000
	2000-2500	2000-2500

04	Component series 10 ... 19 (10 ... 19: unchanged installation and connection dimensions)	1X
----	------------------------------------------------------------------------------------------	-----------

Seal

05	NBR seal	M
	FKM seal	V

Amending information

06	Breathing filter with oil mist separator (only size 0040-0100)	FN
----	----------------------------------------------------------------	-----------

Seal kit

Material no.	Description
R928051474	D10TDN0040-0100-1X/-M
R928051475	D10TDN0160-0250-1X/-M
R928051476	D10TDN0400-0630-1X/-M
R928051478	D10TDN1000-1X/-M
R928051479	D10TD2000-2500-1X/-M
R928051993	D10TDN0040-0100-1X/-V
R928051994	D10TDN0160-0250-1X/-V
R928051995	D10TDN0400-0630-1X/-V
R928051996	D10TDN1000-1X/-V
R928051997	D10TD2000-2500-1X/-V
R928053141	D10TDN0040-0100-1X/-M-FN
R928053142	D10TDN0040-0100-1X/-V-FN

Assembly, commissioning, maintenance

Installation

The max. operating pressure of the system must not exceed the max. admissible operating pressure of the filter (see nameplate).

Notice:

When using a manometer, the maximum permissible operating pressure is reduced to 6 bar [87 psi].

Before the assembly, the hole pattern of the tank must be compared to the dimensions from the “Dimensions” chapter.

It is strongly recommended to secure drain pipes longer than 400 mm with an inside tank mount bracket in order to avoid vibrations due to fluid flow in the tank. Additionally, it is necessary for maintenance work to ensure the filter bowl and the outlet pipe are pulled out of the filter head together.

During assembly of the filter (see also chapter “Tightening torque”), the flow direction (direction arrows) and the required servicing height of the filter element (see chapter “Dimensions”) are to be considered. With frame sizes 1000 - 2500, the lifting eyes can be used as assembly aid. Perfect functioning is only guaranteed in the installation position filter bowl vertically downwards and ON the tank. The maintenance indicator must be arranged so it is easily viewed in operation.

Remove the plastic plugs in the filter inlet and outlet. Ensure that the system is assembled without tension stress. The optional electronic maintenance indicator is connected via the electronic switching element with 1 or 2 switching points, which is attached to the mechanical optical maintenance indicator and held by means of the locking ring.

Commissioning

Commission the system.

Switch the filter into the operating position; to do so, switch the switching lever to one of the two end positions. The filter in use is identified by the flow symbol on the changeover handle.

Notice:

There is no bleed function provided at the filter.

Maintenance

- ▶ If at operating temperature, the red indicator pin reaches out of the mechanical optical maintenance indicator and/or if the electronic switching element opens / closes the circuit, the filter element is contaminated and needs to be replaced or cleaned respectively.
- ▶ The material number of the corresponding replacement filter element is indicated on the nameplate of the complete filter. It must comply with the material number on the filter element.
- ▶ Move the switching lever to the opposite end position in order to switch to the clean filter side. Observe the switching symbol on the switching lever and/or the switch-over.
- ▶ Unscrew the filter cover and/or loosen the screws and remove the filter over upwards.

Notice:

Note that elements with lower filtration ratings may take slightly longer to discharge the residual oil. If there is still residual oil in the filter bowl, the fluid has to be collected in a separate tank.

- ▶ Remove the filter element together with the filter bowl. From frame size 0160, the filter bowls are equipped with removal brackets.
- ▶ Remove the filter element from the spigot in the filter bowl by rotating it slightly.
- ▶ Clean the filter components, if necessary.
- ▶ Check the seals at filter cover and filter bowl for damage and replace them if necessary. For suitable seal kits, refer to chapter “Spare parts”.
- ▶ Filter elements made of wire mesh can be cleaned. The efficiency of the cleaning process depends on the type of dirt and the amount of the pressure differential before the filter element exchange. If the pressure differential after the filter element exchange exceeds 150% of the value of a brand-new filter element, the filter element made of wire mesh (G...) also needs to be replaced. For detailed cleaning instructions, see data sheet 51420.
- ▶ Install the new or cleaned filter element on the spigot again by slightly rotating it.
- ▶ The filter is to be assembled in reverse order.
- ▶ The torque specifications (“Tightening torques” chapter) are to be observed.
- ▶ During the filter element exchange, the breathing filter element should be exchanged manually if equipped. (only with NG 0040-0100)

Assembly, commissioning, maintenance

WARNING!

- ▶ Assemble and disassemble only with depressurized system! For the filter element exchange refer to “Maintenance”.
- ▶ Filter is pressurized.
- ▶ Do not operate the switching lever during the filter element exchange.
- ▶ Do not exchange the optical/mechanical maintenance indicator while the filter is under pressure!
- ▶ If the flow direction is not considered during assembly, the filter element will be destroyed. Particle contaminates could enter the system and damage the downstream components.

Important:

- ▶ All maintenance of the filter should be performed by trained specialists.
- ▶ Proper function and safety are only guaranteed if original Bosch Rexroth filter elements and spare parts are used.
- ▶ Warranty becomes void if the delivered item is changed by the ordering party or third parties or improperly mounted, installed, maintained, repaired, used or exposed to environmental condition that do not comply with the installation conditions.

Tightening torques

Tank mounting without installation plate

Series 10TD...	N0040	N0063	N0100	N0160	N0250	N0400	N0630	N1000	2000	2500	
Tank mounting screw	M10 x 30			M10 x 25			M12 x 25				
Quantity	4			8							
Recommended property class of screw	8.8										
Tightening torque with $\mu_{\text{total}} = 0.14$	Nm [lb-ft]		$21 \pm 10\%$ [16 ± 10%]					$37 \pm 10\%$ [27 ± 10%]			

Tank mounting with installation plate

Series 10TD...	N0040	N0063	N0100	N0160	N0250	N0400	N0630	N1000	2000	2500
Installation plate screw (hexagon socket head cap screw)	-			M10 x 20			M10 x 25			
Quantity	-			8						
Recommended property class of screw	-			8.8						
Tightening torque with $\mu_{\text{total}} = 0.14$	Nm [lb-ft]		-			$21 \pm 10\%$ [16 ± 10%]				

Filter cover

Series 10TD...	N0040	N0063	N0100	N0160	N0250	N0400	N0630	N1000	2000	2500
Filter cover screw	-			M10			M12			
Quantity	-			4						
Recommended property class of screw	-			8.8						
Tightening torque with $\mu_{\text{total}} = 0.14$	Nm [lb-ft]		manually to the stop $20 \pm 10\%$ ¹⁾ [15 ± 10%]		$21 \pm 10\%$ [16 ± 10%]		$37 \pm 10\%$ [27 ± 10%]			

Maintenance indicator

Series 10TD...	N0040	N0063	N0100	N0160	N0250	N0400	N0630	N1000	2000	2500
Maintenance indicator, mechanical optical, aluminum, V...	Nm [lb-ft]		Max. 50 [37]							
Maintenance indicator, mechanical optical, PA, P2.2	Nm [lb-ft]		35 ± 3 [26 ± 3%]							
Cubic connector screw switching element EN-175301-803	Nm [lb-ft]		M3/0.5 [0.4]							

¹⁾ Re-tighten using an open-end wrench (SW19), if necessary

Directives and standardization

Classification according to the Pressure Equipment Directive

The return line filters for hydraulic applications according to 51454 are pressure holding equipment according to article 1, section 2.1.4 of the Pressure Equipment Directive 97/23/EC (PED). However, based on the exception in article 1, section 3.6 of the PEG, hydraulic filters are exempt from the PED if they are not classified higher than category I (guideline 1/19).

Use in explosive areas according to directive 94/9/EC (ATEX)

The tank mounted return line filters according to 51454 are not equipment or components in the sense of directive 94/9/EC and are not provided with a CE mark. It has been proven with the ignition risk analysis that these return line filters do not have own ignition sources acc. to DIN EN 13463-1:2009.

According to DIN EN 60079-11:2012, electronic maintenance indicators with a switching point:

WE-1SP/M12x1 R928028409

WE-1SP-EN175301-803 R928036318

are simple, electronic operating equipment that do not have an own voltage source.

The fluids from the chapter “Compatibility with approved pressure fluids” were considered for the classification. The intended use is only permitted with fluids in group 2 and within the specified operating limits (see “Specifications”). These filters do not receive a CE mark.



Notice:

Maintenance Indicators with EC type examination certificate on request.

This simple, electronic operating equipment may - according to DIN EN 60079-14:2012 - in intrinsically safe electric circuits (Ex ib) be used in systems without marking and certification.

The tank mounted return line filters and the electronic maintenance indicators described here can be used for the following explosive areas:

	zone suitability	
Gas	1	2
Dust	21	22

Complete filter with mech./opt. Maintenance indicator

Use /assignment			Gas 2G	Dust 2D
Assignment ¹⁾			Ex II 2G c IIC T6	Ex II 2D c IIC T6
Conductivity of the medium	pS/m	min	300	
Dust accumulation		max	–	0.5 mm

electronic switching element in the intrinsically safe electric circuit

Use /assignment			Gas 2G	Dust 2D
Assignment			Ex II 2G Ex ib IIB T4 Gb	Ex II 2D Ex ib IIIC T100 °C Db
Perm. intrinsically safe electric circuits			Ex ib IIC, Ex ic IIC	Ex ib IIIC
Technical data			Values only for intrinsically safe electric circuit	
Switching voltage	Ui	max	150 V AC/DC	
Switching current	Ii	max	1,0 A	
Switching power	Pi	max	1.3 W T4 T _{max} 40 °C	750 mW T _{max} 40 °C
		max	1.0 W T4 T _{max} 80 °C	550 mW T _{max} 100 °C
Surface temperature ²⁾		max	–	100 °C
inner capacity	Ci		negligible	
inner inductivity	Li		negligible	
Dust accumulation		max	–	0.5 mm

¹⁾ The temperature depends on the temperature of the medium in the filter and must not exceed the value specified here.

²⁾ TX = max. temperature range: see chapter “Technical data”

Directives and standardization

Possible circuit according to DIN EN 60079-14

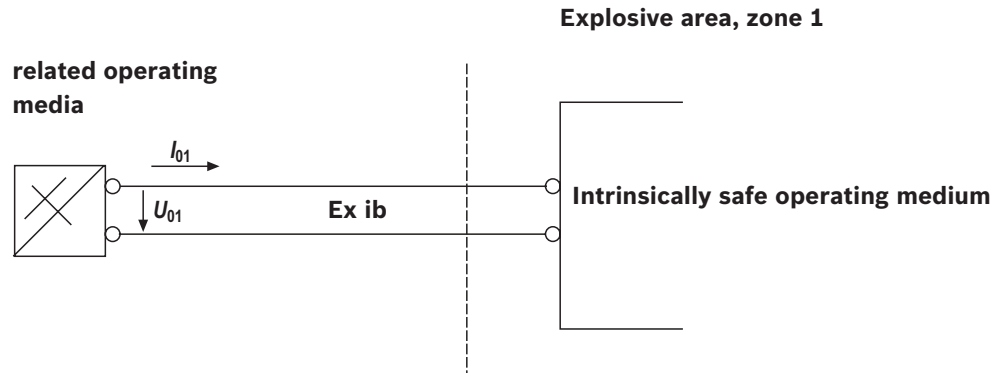

⚠ WARNING!

- ▶ Explosion hazard due to high temperature! The surface temperature of the filter depends on the temperature of the medium in the hydraulic circuit and must not exceed the value specified here. Measures are to be taken so that in the explosive area, the max. admissible ignition temperature is not exceeded.
- ▶ When using the tank mounted return line filters according to 51454 in explosive areas, appropriate potential equalization has to be ensured. The filter is preferably to be grounded via the mounting screws. It has to be noted in this connection that paintings and oxidic protective layers are not electrically conductive.
- ▶ During filter element exchanges, the packaging material is to be removed from the replacement element outside the explosive area

👉 Important:

- ▶ Maintenance only by trained specialists, instruction by the machine end-user acc. to DIRECTIVE 1999/92/EC appendix II, section 1.1
- ▶ Functional and safety warranty is only applicable when using genuine Rexroth spare parts

Environmental safety and recycling

- ▶ The used filter element should be disposed of in accordance with the respective country-specific legal regulations of environmental protection.
- ▶ After completion of the filter life, the components of the filter, in accordance with the respective country-specific legal regulations of environmental protection, are recycled.

Notes

Bosch Rexroth AG
Werk Ketsch
Hardtwaldstr. 43
68775 Ketsch, Germany
Telefon +49 (0) 62 02/603-0
filter-support@boschrexroth.de
www.boschrexroth.de

© This document, as well as the data, specifications and other information set forth in it, are the exclusive property of Bosch Rexroth AG. It may not be reproduced or given to third parties without the consent of Bosch Rexroth AG. The data specified above only serve to describe the product. No statements concerning a certain condition or suitability for a certain application can be derived from our information. The information given does not release the user from the obligation of own judgment and verification. It must be remembered that our products are subject to a natural process of wear and aging.