

Compact cylinder

SDA Series

SDAD

Φ12、Φ16

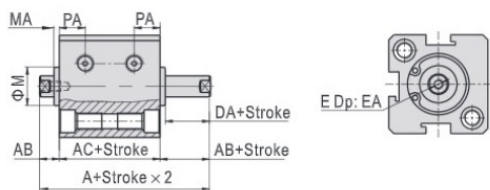

SDAJ

Φ12、Φ16

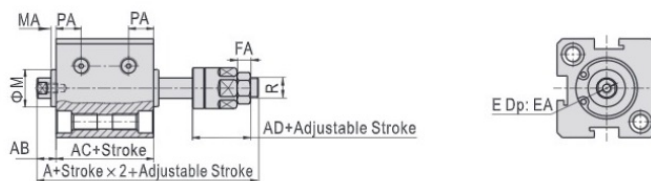

Φ20~Φ100

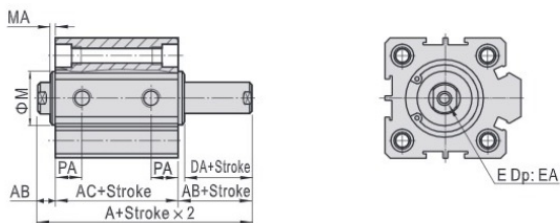

Φ20~Φ100

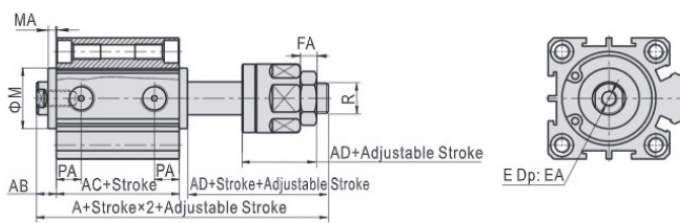

Bore size\Item	A		AC		AB	DA
	Without magnet	With magnet	Without magnet	With magnet		
12	27	17	37	27	5	4
16	29.5	18.5	39.5	28.5	5.5	4
20	30.5	19.5	40.5	29.5	5.5	4
25	33	21	43	31	6	4
32	38.5	24.5	48.5	34.5	7	4
40	40	26	50	36	7	4
50	46	28	56	38	9	5
63	50	32	60	42	9	5
80	63	41	73	51	11	6
100	75	51	85	61	12	7

Bore size\Item	A		AC		AB	AD	E
	Without magnet	With magnet	Without magnet	With magnet			
12	40	17	50	27	5	17	M3 × 0.5
16	42.5	18.5	52.5	28.5	5.5	17	M3 × 0.5
20	47.5	19.5	57.5	29.5	5.5	21	M4 × 0.7
25	54	21	64	31	6	25	M5 × 0.8
32	61.5	24.5	71.5	34.5	7	27	M6 × 1.0
40	64	26	74	36	7	28	M8 × 1.25
50	70	28	80	38	9	29	M10 × 1.5
63	74	32	84	42	9	29	M10 × 1.5
80	92.5	41	102.5	51	11	35.5	M14 × 1.5
100	110.5	51	120.5	61	12	42.5	M18 × 1.5

Bore size\Item	E	EA		M	MA	PA	
		St≤10	St>10			St=5	St>5
12	M3 × 0.5	6	6	10.2	1	5.5	6.3
16	M3 × 0.5	6	6	11	1.5	6.5	7.3
20	M4 × 0.7	8(6.5 for St=5)	15	1.5	7.5	7.5	7.5
25	M5 × 0.8	10(7 for St=5)	17	2	8	8	8
32	M6 × 1.0	8	12	22	3	8	9
40	M8 × 1.25	8	12	28	3	8	10
50	M10 × 1.5	8	15	38	4	8	10.5
63	M10 × 1.5	10	15	40	4	9.5	11.8
80	M14 × 1.5	13	20	45	5	11.5	14.5
100	M18 × 1.5	18	20	55	5	16	20.5

Bore size\Item	EA		FA	M	MA	PA		R
	St≤10	St>10				St=5	St>5	
12	6	6	4	10.2	1	5.5	6.3	M5 × 0.8
16	6	6	4	11	1.5	6.5	7.3	M5 × 0.8
20	8(6.5 for St=5)	15	5	15	1.5	7.5	7.5	M6 × 1.0
25	10(7 for St=5)	17	6	17	2	8	8	M8 × 1.25
32	8	12	6	22	3	8	9	M10 × 1.25
40	8	12	7	28	3	8	10	M12 × 1.25
50	8	15	8	38	4	8	10.5	M16 × 1.5
63	10	15	8	40	4	9.5	11.8	M16 × 1.5
80	13	20	10	45	5	11.5	14.5	M20 × 1.5
100	18	20	13.5	55	5	16	20.5	M27 × 2.0

Note) The unmarked dimension is the same as SDA standard type.
Please refer to Page 126 for the dimension of male thread.

Note) The unmarked dimension is the same as SDA standard type.
Please refer to Page 126 for the dimension of male thread.

Standard cylinder(Tie-rod)

SC Series

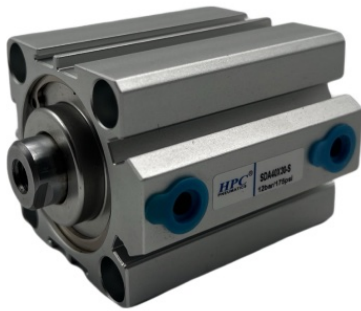

Symbol

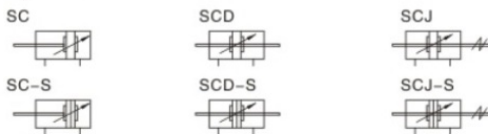

Product feature

- Standard cylinder manufactured by our enterprise;
- The seal of piston adopts heterogeneous two way seal structure. Its dimension is tight and it has the function of oil reservation;
- It is tie rod cylinder. The cylinder barrel and front/rear cap is jointed by tie rods with high reliability;
- Compared with ISO15552 standard cylinder, SC series cylinder with the same bore size is shorter;
- The buffer adjustment of cylinder is smooth and steady;
- Cylinders and mounting accessories with several specifications are optional;
- The seal material with high temperature resistance is adopted to guarantee the normal operation of cylinder at 150°C.

Specification

Bore size	mm	32	40	50	63	80	100
Acting type	Double acting						
Fluid	Air(to be filtered by 40um filter element)						
Mounting type	SC	Basic FA FB CA CB LB TC TF					
	SCD、SCJ	Basic FA LB TC TF					
Operating pressure	0.1-1.0MPa(14-145Psi)						
Proof pressure	1.5MPa(215Psi)						
Temperature	°C	-20-80					
Speed range	mm/s	30-800					
Stroke tolerance		0-250 ^{+1.0} ₀	251-1000 ^{+1.4} ₀			1001-1500 ^{+1.8} ₀	
Cushion type	Variable cushion						
Adjustable cushion stroke mm		21				28	29
Port size	①	1/8"	1/4"	3/8"		1/2"	

① PT thread, NPT thread and G thread are available;
Add: Refer to PVI-39-VI-50 for detail of sensor switch.

Stroke

Series Name	Bore size (mm)	Standard stroke																Max. stroke	Available stroke
		25	50	75	80	100	125	150	175	200	225	250	300	350	400	450	500		
SC	32																	1000	2000
	40																	1200	2000
SCD	50																	1200	2000
	63	25	50	75	80	100	125	150	175	200	225	250	300	350	400	1500	2000		
SCJ	80	450	500	600	700	800	900	1000	1500	2000									
	100																	1500	2000

Note: if the stroke is ≥ 1600mm within the maximum stroke scope, it is treated as non-standard one. Please contact the company for other special strokes.

Ordering code



Thread type

P: PT
T: NPT
G: G

Seal material

Blank: TPU
H: Viton
N: NBR

Adjustable stroke

10: 10mm
20: 20mm
30: 30mm
40: 40mm
50: 50mm
75: 75mm
100: 100mm

Magnet

S: With magnet
Blank: Without magnet

Model

SC: Double acting type
SCD: Double rod type
SCJ: Adjustable stroke type

Mounting type

Mounting type	Available series	Memo
Blank	SC SCD SCJ	
LB	SC SCD SCJ	
FA	SC SCD SCJ	
FB	SC	
CA	SC	
CB	SC	
TC	SC SCD SCJ	Be used with TF

① Please see PIII-23-III-24 for detail.

Compact cylinder

SDA Series

Inner structure and material of major parts

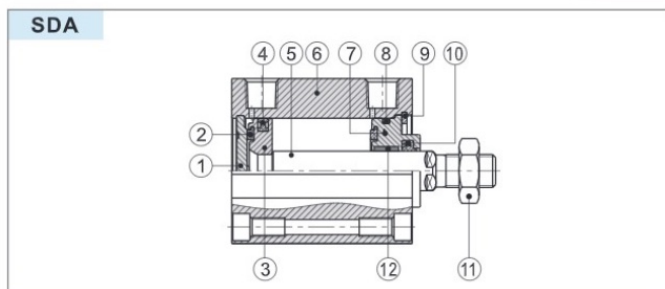

NO.	Item	Material
1	Back cover	No(Φ 12, 16)/Aluminum alloy(Others)
2	Bumper	NBR
3	Piston	Brass(Φ 12, 16)/Aluminum alloy(Others)
4	Piston seal	NBR
5	Piston rod	Carbon steel with 20 μ m chrome plated
6	Body	Aluminum alloy
7	Front cover	Aluminum alloy
8	O-ring	NBR
9	C clip	Spring steel
10	Front cover packing	NBR
11	Piston nut	Carbon steel
12	Bushing	No(Φ 12~32)/Wear resistant material(Others)

Dimensions

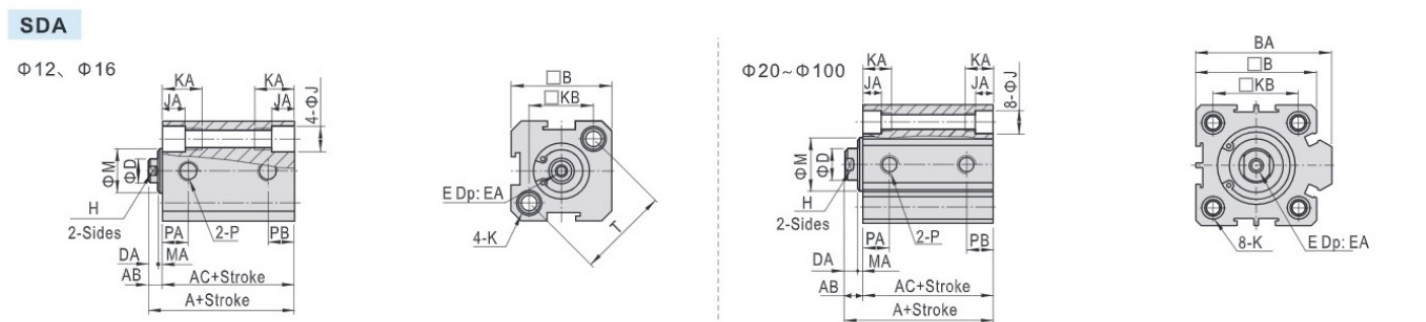

Item Bore size	A		AC		AB	B	BA	D	DA	E	EA	H	J	JA	K	KA	KB	M	MA	P	PA		PB		T
	Without magnet	With magnet	St=5	St>5																	St=5	St>5			
12	22	17	32	27	5	25	-	6	4	M3×0.5	6	5	6.5	4.5	M5×0.8Thru.hole:Φ4.2	12	16.3	10.2	1	M5×0.8	7.5	7.5	5	5	23
16	24	18.5	34	28.5	5.5	29	-	6	4	M3×0.5	6	5	6.5	4.5	M5×0.8Thru.hole:Φ4.2	12	19.8	11	1.5	M5×0.8	8	8	5	5.5	28
20	25	19.5	35	29.5	5.5	34	36	8	4	M4×0.7	8	6	6.5	4.5	M5×0.8Thru.hole:Φ4.2	14	24	13	1.5	M5×0.8	8	9	5	5.5	-
25	27	21	37	31	6	40	42	10	4	M5×0.8	10	8	8.2	5.5	M6×1.0Thru.hole:Φ5.2	15	28	17	2	M5×0.8	9	9	5.5	5.5	-
32	31.5	24.5	41.5	34.5	7	44	50	12	4.5	M6×1.0	12	10	8.2	5.5	M6×1.0Thru.hole:Φ5.2	16	34	22	2.5	1/8"	9	9	6.5	9	-
40	33	26	43	36	7	52	58.5	16	4	M8×1.25	12	14	10.5	6.5	M8×1.25Thru.hole:Φ6.7	20	40	28	3	1/8"	9.5	9.5	7.5	7.5	-
50	37	28	47	38	9	62	71.5	20	5	M10×1.5	15	17	10.5	6.5	M8×1.25Thru.hole:Φ6.7	25	48	38	4	1/4"	8	10.5	8	10.5	-
63	41	32	51	42	9	75	84.5	20	5	M10×1.5	15	17	10.5	6.5	M8×1.25Thru.hole:Φ6.7	25	60	40	4	1/4"	9.5	12	9.5	11	-
80	52	41	62	51	11	94	104	25	6	M14×1.5	20	22	17	11	M12×1.75Thru.hole:Φ10.4	25	74	45	5	3/8"	11.5	14.5	11.5	14.5	-
100	63	51	73	61	12	114	124	32	7	M18×1.5	20	27	19	13	M14×2.0Thru.hole:Φ12.4	30	90	55	5	3/8"	16	20.5	16	20.5	-

Male thread

Φ12, Φ16

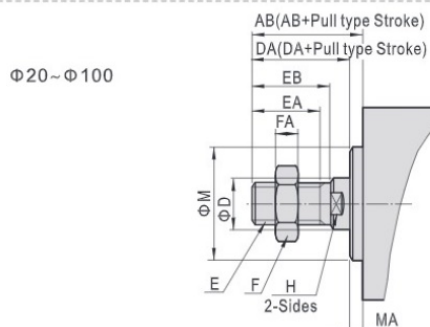
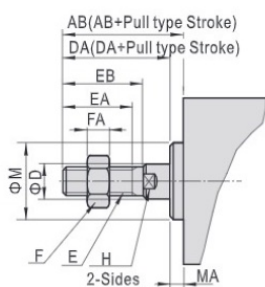

Bore size\Item	AB	D	DA	E	EA	EB	F	FA	H	M	MA	
											SDAD\SDAJ	Others
12	17	6	16	M5×0.8	10	12	8	4	5	10.2	1	1
16	17.5	6	16	M5×0.8	10	12	8	4	5	11	1.5	1.5
20	20.5	8	19	M6×1.0	13	15	10	5	6	13	1.5	1.5
25	23	10	21	M8×1.25	15	17	12	6	8	17	2	2
32	25	12	22	M10×1.25	15	18	17	6	10	22	3	2.5
40	35	16	32	M14×1.5	25	28	19	8	14	28	3	3
50	37	20	33	M18×1.5	25	28	27	11	17	38	4	4
63	37	20	33	M18×1.5	25	28	27	11	17	40	4	4
80	44	25	39	M22×1.5	30	33	32	13	22	45	5	5
100	50	32	45	M26×1.5	35	38	36	13	27	55	5	5

Compact cylinder—SDA Series

Compendium of SDA Series

Manufactured by our enterprise

Magnetic switch slots around the cylinder body
There are magnetic switch slots around the cylinder body convenient to install inducting switch.

Two kinds of rod type

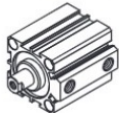

Female thread









Male thread

Ten bore size are available
Bore size: 12, 16, 20, 25, 32, 40, 50, 63, 80, 100

Compact structure
Riveted structure is adopted to connect the cylinder body and back cover, and piston and piston rod to make it compact and reliable

Multi-type cylinder

SDA: Compact cylinder (Double acting)	
SSA: Compact cylinder (Single acting-push)	
STA: Compact cylinder (Single acting-pull)	
SDAD: Compact cylinder (Double rod)	
SDAJ: Compact cylinder (Adjustable stroke)	
SDAT: Compact cylinder (Duplex type)	
SDAW: Compact cylinder (Duplex-end type)	

Criteria for selection: Cylinder thrust

Unit: Newton(N)

Bore size	Rod size	Acting type	Pressure area(mm ²)	Operating pressure(MPa)							
				0.1	0.2	0.3	0.4	0.5	0.6	0.7	
12	6	Single acting	Push side	113.1	-	12.6	23.9	35.2	46.5	57.9	69.2
			Pull side	84.8	-	7.0	15.4	23.9	32.4	40.9	49.4
		Double acting	Push side	113.1	-	22.6	33.9	45.2	56.5	67.9	79.2
			Pull side	84.8	-	17.0	25.4	33.9	42.4	50.9	59.4
16	6	Single acting	Push side	201.1	-	20.2	40.3	60.4	80.5	100.6	120.7
			Pull side	172.8	-	14.6	31.8	49.1	66.4	83.7	101.0
		Double acting	Push side	201.1	-	40.2	60.3	80.4	100.5	120.6	140.7
			Pull side	172.8	-	34.6	51.8	69.1	86.4	103.7	121.0
20	8	Single acting	Push side	314.2	-	39.8	71.2	102.7	134.1	165.5	196.9
			Pull side	263.9	-	29.8	56.2	82.6	108.9	135.3	161.7
		Double acting	Push side	314.2	-	62.8	94.2	125.7	157.1	188.5	219.9
			Pull side	263.9	-	52.8	79.2	105.6	131.9	158.3	184.7
25	10	Single acting	Push side	490.9	-	69.7	118.8	167.8	216.9	266.0	315.1
			Pull side	412.3	-	54.0	95.2	136.4	177.7	218.9	260.1
		Double acting	Push side	490.9	-	98.2	147.3	196.3	245.4	294.5	343.6
			Pull side	412.3	-	82.5	123.7	164.9	206.2	247.4	288.6
32	12	Single acting	Push side	804.2	-	105.3	185.8	266.2	346.6	427.0	507.5
			Pull side	691.2	-	82.7	151.8	221.0	290.1	359.2	428.3
		Double acting	Push side	804.2	-	160.8	241.3	321.7	402.1	482.5	563.0
			Pull side	691.2	-	138.2	207.3	276.5	345.6	414.7	483.8
40	16	Single acting	Push side	1256.6	-	168.6	294.3	420.0	545.6	671.3	796.9
			Pull side	1055.6	-	128.4	234.0	339.5	445.1	550.6	656.2
		Double acting	Push side	1256.6	125.7	251.3	377.0	502.7	628.3	754.0	879.6
			Pull side	1055.6	105.6	211.1	316.7	422.2	527.8	633.3	738.9
50	20	Single acting	Push side	1963.5	89.3	285.7	482.0	678.4	874.7	1071.1	1267.4
			Pull side	1649.3	57.9	222.9	387.8	552.7	717.7	882.6	1047.5
		Double acting	Push side	1963.5	196.3	392.7	589.0	785.4	981.7	1178.1	1374.4
			Pull side	1649.3	164.9	329.9	494.8	659.7	824.7	989.6	1154.5
63	20	Single acting	Push side	3117.2	135.7	447.4	759.2	1070.9	1382.6	1694.3	2006.1
			Pull side	2803.1	104.3	384.6	664.9	945.2	1225.5	1505.9	1786.2
		Double acting	Push side	3117.2	311.7	623.4	935.2	1246.9	1558.6	1870.3	2182.1
			Pull side	2803.1	280.3	560.6	840.9	1121.2	1401.5	1681.9	1962.2
80	25	Double acting	Push side	5026.5	502.7	1005.3	1508.0	2010.6	2513.3	3015.9	3518.6
			Pull side	4535.7	453.6	907.1	1360.7	1814.3	2267.8	2721.4	3175.0
		Single acting	Push side	7854.0	785.4	1570.8	2356.2	3141.6	3927.0	4712.4	5497.8
			Pull side	7049.7	705.0	1409.9	2114.9	2819.9	3524.9	4229.8	4934.8

Installation and application



1. When load changes in the work, the cylinder with abundant output capacity shall be selected.
2. Relative cylinder with high temperature resistance or corrosion resistance shall be chosen under the condition of high temperature or corrosion.
3. Necessary protection measure shall be taken in the environment with higher humidity, much dust or water drops, oil dust and welding dregs.
4. Dirty substances in the pipe must be eliminated before cylinder is connected with pipeline to prevent the entrance of particles into the cylinder.
5. The medium used by cylinder shall be filtered to 40 μm or below.
6. As both of the front cover and piston of the cylinder are short, typically too large stroke can not be selected.
7. Anti-freezing measure shall be adopted under low temperature environment to prevent moisture freezing.
8. The cylinder shall avoid the influence of side load in operation to maintain the normal work of cylinder and extend the service life.
9. If the cylinder is dismantled and stored for a long time, please conduct anti-rust treatment to the surface. Anti-dust caps shall be added in air inlet and outlet ports. The front and back cover can not be dismantled, which shall be especially noticed.

Compact cylinder

SDA Series

SSA

Φ12、Φ16

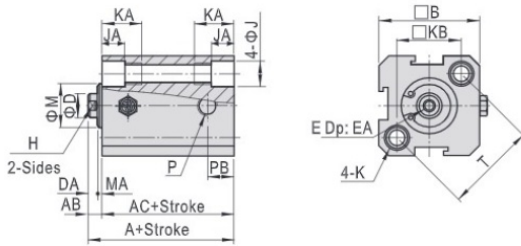

STA

Φ12、Φ16

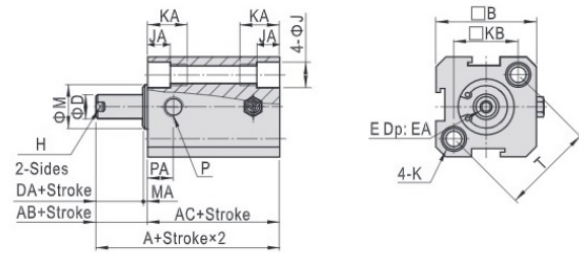

Φ20~Φ63

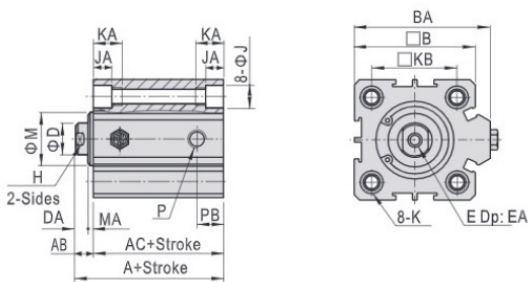

Φ20~Φ63

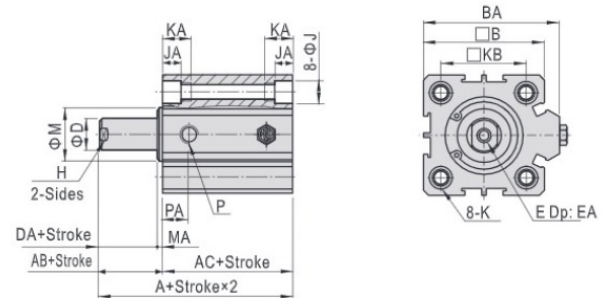

Bore size\Item	A(Without magnet)		A(With magnet)		AB	AC(Without magnet)		AC(With magnet)		B	BA
	St≤10	St>10	St≤10	St>10		St≤10	St>10	St≤10	St>10		
12	32	42	42	52	5	27	37	37	47	25	-
16	34	44	44	54	5.5	28.5	38.5	38.5	48.5	29	-
20	35	45	45	55	5.5	29.5	39.5	39.5	49.5	34	36
25	37	47	47	57	6	31	41	41	51	40	42
32	41.5	51.5	51.5	61.5	7	34.5	44.5	44.5	54.5	44	50
40	43	53	53	63	7	36	46	46	56	52	58.5
50	47	57	57	67	9	38	48	48	58	62	71.5
63	51	61	61	71	9	42	52	52	62	75	84.5

Bore size\Item	D	DA	E	EA	H	J	JA	K			KA	KB	M	MA	P	PA	PB	T
12	6	4	M3×0.5	6	5	6.5	4.5	M5×0.8 Thru.hole: Φ4.2			12	16.3	10.2	1	M5×0.8	7.5	5	23
16	6	4	M3×0.5	6	5	6.5	4.5	M5×0.8 Thru.hole: Φ4.2			12	19.8	11	1.5	M5×0.8	8	5.5	28
20	8	4	M4×0.7	8	6	6.5	4.5	M5×0.8 Thru.hole: Φ4.2			14	24	13	1.5	M5×0.8	9	5.5	-
25	10	4	M5×0.8	10	8	8.2	5.5	M6×1.0 Thru.hole: Φ5.2			15	28	17	2	M5×0.8	9	5.5	-
32	12	4	M6×1.0	12	10	8.2	5.5	M6×1.0 Thru.hole: Φ5.2			16	34	22	2.4	1/8"	9	9	-
40	16	4	M8×1.25	12	14	10.5	6.5	M8×1.25 Thru.hole: Φ6.7			20	40	28	3	1/8"	9.5	7.5	-
50	20	5	M10×1.5	15	17	10.5	6.5	M8×1.25 Thru.hole: Φ6.7			25	48	38	4	1/4"	10.5	10.5	-
63	20	5	M10×1.5	15	17	10.5	6.5	M8×1.25 Thru.hole: Φ6.7			25	60	40	4	1/4"	12	11	-

Note) Please refer to Page 126 for the dimension of male thread.

Compact cylinder

SDA Series



Symbol

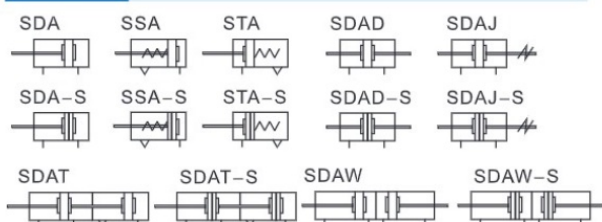

Product feature

1. Manufactured by our enterprise.
2. Riveted structure is adopted to connect the cylinder body and back cover, and piston and piston rod to make it compact and reliable;
3. The inner diameter of the body is treated with rolling followed by the treatment of hard anodizing, forming an excellent abrasion resistance and durability.
4. The seal of piston adopts heterogeneous two-way seal structure. It has compact dimension and the function of grease reservation.
5. Compact structure can effectively save installation space.
6. There are magnetic switch slots around the cylinder body, which is convenient to install sensor switch
7. Mounting accessories with various specifications are optional.

Specification

Bore size(mm)		12	16	20	25	32	40	50	63	80	100	
Acting type		Double acting										
		Single acting_Push type、Single acting_Pull type										
Fluid		Air(to be filtered by 40 μm filter element)										
Operating pressure	Double acting	0.15~1.0MPa(22~145psi)(1.5~10.0bar)										
	Single acting	0.2~1.0MPa(28~145psi)(2.0~10.0bar)										
Proof pressure		1.5MPa(215psi)(15bar)										
Temperature °C		-20~70										
Speed range mm/s		Double acting: 30~500					Single acting: 50~500					
Stroke tolerance		Stroke≤100 $+1.0_0$					Stroke>100 $+1.5_0$					
Cushion type		Bumper										
Port size [Note1]		M5×0.8			1/8"			1/4"		3/8"		

[Note1] PT thread is available.
Add) Refer to P353 for detail of sensor switch.

Stroke

Bore size (mm)		Standard stroke (mm)										Max.std stroke												
12	Double acting	With magnet	5	10	15	20	25	30	35	40	45	50	50											
		Without magnet	5	10	15	20	25	30	35	40	45	50	55	60	60									
16	Single acting		5	10	15	20	25	30	30					30										
		Double acting	5	10	15	20	25	30	35	40	45	50	55	60	65	70	75	80	85	90	90			
20	Double acting	With magnet	5	10	15	20	25	30	35	40	45	50	55	60	65	70	75	80	85	90	100	100		
		Without magnet	5	10	15	20	25	30	35	40	45	50	55	60	65	70	75	80	85	90	100	100		
25	Single acting		5	10	15	20	25	30	30													30		
		Double acting	5	10	15	20	25	30	35	40	45	50	55	60	65	70	75	80	85	90	100	110	120	120
32	Double acting	With magnet	5	10	15	20	25	30	35	40	45	50	55	60	65	70	75	80	85	90	100	110	120	120
		Without magnet	5	10	15	20	25	30	35	40	45	50	55	60	65	70	75	80	85	90	100	110	120	130
40	Single acting		5	10	15	20	25	30	30															30
		Double acting	5	10	15	20	25	30	35	40	45	50	55	60	65	70	75	80	85	90	100	110	120	120
50	Double acting	With magnet	5	10	15	20	25	30	35	40	45	50	55	60	65	70	75	80	85	90	100	110	120	120
		Without magnet	5	10	15	20	25	30	35	40	45	50	55	60	65	70	75	80	85	90	100	110	120	130

- Note) 1. Please contact the company for other special strokes.
2. The dimensions of non-std stroke cylinder has the same dimensions as the next longer stroke std. stroke cylinder. e.g. 23mm stroke cylinder has the same dimensions of 25 std. stroke cylinder.

Ordering code

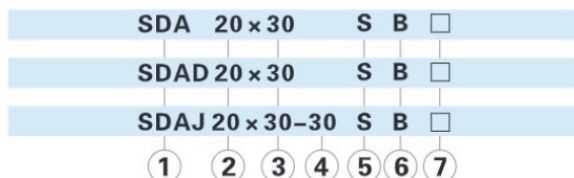

①Model	②Bore size	③Stroke	④Adjustable Stroke	⑤Magnet	⑥Rod type	⑦Thread type [Note 1]
SDA: Compact cylinder(Double acting)	12 16 20 25 32 40 50 63 80 100	Refer to stroke table for details	No this code	Blank: Without magnet S: With magnet	Blank: Female thread B: Male thread	Blank: PT
SSA: Compact cylinder(Single acting-push)	12 16 20 25 32 40 50 63					
STA: Compact cylinder(Single acting-pull)	12 16 20 25 32 40 50 63					
SDAD: Compact cylinder(Double rod)	12 16 20 25 32 40 50 63 80 100					
SDAJ: Compact cylinder(Adjustable stroke)	12 16 20 25 32 40 50 63 80 100		10 20 30 40 50 75 100			

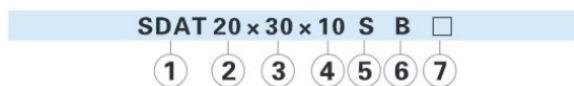

①Model	②Bore size	③Stroke 1	④Stroke 2	⑤Magnet	⑥Rod type	⑦Thread type [Note 1]
SDAT: Compact cylinder (Duplex type)	12 16 20 25 32 40 50 63 80 100	Refer to stroke table for details	Refer to stroke table for details	Blank: Without magnet S: With magnet	Blank: Female thread B: Male thread	Blank: PT
SDAW: Compact cylinder(Duplex-end type)	12 16 20 25 32 40 50 63 80 100					

[Note1] Standard thread is blank here.